



# **AAR Intermodal Interchange Rules**

## **Including Billing and Repair Procedures**

Governing the Interchange of, Repairs to, and  
Settlement for, Units Used in  
Intermodal Service

Effective March 9, 2020

**Association of American Railroads**

Safety and Operations  
425 Third Street SW  
Washington, DC 20024



# AAR Intermodal Interchange Rules

## Contents

Preamble .....	XV
Preface .....	XV
<b>SECTION A—GENERAL CONDITIONS GOVERNING ACCEPTANCE AND DELIVERY OF UNITS IN INTERCHANGE .....</b>	<b>1</b>
1. Equipment Specifications.....	1
2. Hazmat Placarding.....	1
3. Loading Practices .....	1
4. Clearance Profile .....	1
5. Weight Restrictions .....	1
6. 7-Way Receptacle.....	2
7. Lights .....	3
8. Tank Containers .....	3
a. General .....	3
(1) Compliance Certification.....	3
(2) Loading Conditions .....	3
(3) Tank Data Plate .....	3
(4) Tank and Safety Relief Valve .....	3
(5) Inspection .....	3
b. Interchange of 40 ft Tank Containers .....	3
9. Tank Trailers (“Cargo Tanks”) Carrying Materials .....	4
10. Registration/Permit Holder .....	4
11. Tires .....	4
12. Landing Gear .....	4
13. Licensing.....	4
14. Interchange Placement .....	4
a. Rail Interchange.....	4
b. Rubber Interchange .....	4
15. Defective Units.....	5
16. Flat Rack Containers .....	5
a. Concentrated Loads .....	5
b. Well Placement .....	5
c. Loaded Stacking Configuration .....	5
d. Steel Coils.....	5
e. Load Securement .....	5
f. Gross Weight .....	5
g. Hazmat Restrictions.....	5
h. Empty Collapsed Movement Requirements .....	5
17. Gasoline/LPG Refrigeration Units.....	6
18. Portable Heater Units.....	6
19. Equipment Registration and Reporting .....	6
a. Equipment Initial/Number .....	6
b. TRAIN II and UMLER Reporting .....	6
20. Kingpin Wear Limits .....	6
21. 53 ft Chassis Shipping Units .....	7
a. Definitions .....	7

## AAR Intermodal Interchange Rules

---

b. Well Placement.....	7
c. Weight Consideration.....	7
d. Load Securement .....	7
e. Gross Weight.....	8
f. Stacked Movement Requirements.....	8
22. to 25. Vacant .....	8
<b>SECTION B—TIRES AND TUBES.....</b>	<b>9</b>
26. Conditions at Time of Acceptance and in Interchange .....	9
a. Presence of Tires and Wheel Lugs.....	9
b. Suitability of Tires and Rims .....	9
c. Tire Markings .....	9
d. Lack of Foreign Objects.....	9
e. Inflation and Mating .....	9
27. Maintenance, Repair, and Replacement.....	9
a. Trailer or Chassis Owner Responsibility .....	9
b. Handling Line Responsibility.....	10
(1) Maintenance.....	10
(2) Unserviceable Tires .....	10
(3) Rims .....	10
(4) Serviceable Tubes .....	10
(5) Unserviceable Tubes.....	10
(6) Booting, Sectioning, or Vulcanizing .....	10
(7) Exchanging of Tires.....	10
(8) Multiple Renewals and Replacement at Terminals and by Contracted Vendors .....	10
c. Repair, Renewal, and Replacement Procedures.....	11
(1) Tire Repair Billing Form.....	11
(2) Inspection and Collection of Unserviceable Tires.....	11
d. Retention Period for All Removed Tires (Including Section F Damage) .....	11
28. to 40. Vacant .....	11
<b>SECTION C—LANDING GEARS .....</b>	<b>13</b>
41. Conditions at Time of Acceptance and in Interchange .....	13
a. Load Support .....	13
b. Condition and Securement .....	13
c. Clearances.....	13
42. Maintenance and Operation .....	13
a. Maintenance, Repairs, and Lubrication .....	13
b. Raising Landing Gear .....	13
c. Lowering Landing Gear.....	13
43. to 54. Vacant .....	13
<b>SECTION D—REFRIGERATION AND HEATING .....</b>	<b>15</b>
55. Conditions at Time of Acceptance and in Interchange for Mechanical Units.....	15
a. Stenciling/Fuel type .....	15
b. Satisfactory Operating Condition .....	15
c. Sufficient Oil and fuel .....	15
56. Vacant.....	15

# AAR Intermodal Interchange Rules

---

57. Maintenance .....	15
58. Portable Units .....	15
59. to 70. Vacant .....	15
<b>SECTION E—ACCESSORIES AND SPECIAL EQUIPMENT .....</b>	<b>17</b>
71. Removable Items/Stenciling .....	17
72. Delivering Carrier Responsibility .....	17
73. Handling Carrier Responsibility .....	17
a. Securement of Equipment .....	17
b. Tarpaulins and Bows—Loaded Trailers .....	17
c. Equipment—Empty Trailers .....	18
74. to 80. Vacant .....	18
<b>SECTION F—HANDLING CARRIER RESPONSIBILITY .....</b>	<b>19</b>
81. Damage—By Causes .....	19
82. Damage—Evidential .....	19
g. Tires Slid Flat .....	20
(1) Replacement .....	20
(2) Repair .....	20
83. Losses .....	20
84. Vacant .....	21
85. Vacant .....	21
86. Vacant .....	21
87. Vacant .....	21
<b>SECTION G—ORDINARY MAINTENANCE .....</b>	<b>23</b>
88. Owner Responsibility .....	23
89. to 94. Vacant .....	23
.....	24
<b>SECTION H—REPAIRS AND BILLING .....</b>	<b>25</b>
95. Detailed Procedures .....	25
96. Repairs Exceeding \$750 .....	25
97. Handling Line Responsibility .....	25
98. Repair Cost Limit .....	25
99. Standards for Repair .....	25
100. Vacant .....	25
101. Repairs Requiring Authorization .....	25
102. Citations .....	25
103. to 109. Vacant .....	25
.....	26
<b>SECTION I—AUTHORITY FOR ADJUSTMENT OR TRANSFER OF INTERMODAL EQUIPMENT AND/OR INTERMODAL LADING .....</b>	<b>27</b>
110. Delivering Carrier Responsibility .....	27
a. Compliance with Loading Rules .....	27
b. Adjustment/Transfer of Units and Lading .....	27
(1) Shifted Contents/Improper Loading .....	27
(2) Defective Trailer or Container .....	27

## AAR Intermodal Interchange Rules

---

(3) Defective Car/Attachment.....	27
111. Originating Carrier Responsibility .....	27
a. Transfer—Clearance Violation.....	27
b. Transfer and Delivery—Overload .....	27
c. Damage—Overload .....	27
112. to 119. Vacant .....	27
<b>SECTION J—FORMS AND REPORTS.....</b>	<b>29</b>
120. General Instructions.....	29
121. Unit Interchange and Safety Inspection Report, Form J-1.....	29
122. Unit Damage Responsibility Report, Form J-2 .....	29
a. Preparation and Use of Form .....	29
(1) Damage Form and Distribution.....	29
(2) Recorded Image .....	29
(3) Interchange with Unrepaired Damage Not Covered by Form .....	29
(4) Time Limit for Repair .....	29
(5) Associated Damage .....	30
b. Exception to Form.....	30
c. Provision of Rebill Authority .....	30
123. Form J-3—Authority for Transfer or Adjustment of Intermodal Equipment or Intermodal Lading.....	30
a. Preparation and Use of Form .....	30
b. Expense Responsibility.....	30
124. J-4 Chassis Systematic Maintenance Inspection .....	30
125. Authority for Counterbilling, Form J-5 .....	31
a. Purpose .....	31
b. Completion of Form .....	31
126. FMCSA-PI Certification, Form J-6 .....	31
127. FMCSA-PI Certification Acknowledgment, Form J-7 .....	31
128. AAR Flat File Format .....	31
129. to 135. Vacant .....	31
<b>SECTION K—SETTLEMENT OF DISPUTES AND REVISION OF RULES .....</b>	<b>41</b>
136. Arbitrator of Rules .....	41
137. Interpretation of Rules .....	41
138. Formal Arbitration .....	41
a. Material to be Submitted.....	41
(1) Both Parties Agree to Arbitration .....	41
(2) One Party Declines to Submit to Arbitration .....	41
b. Procedures .....	42
(1) Roles .....	42
(2) Statements .....	42
(3) Presence of Principals.....	42
(4) Finality .....	42
139. Rules Revisions .....	42
140. to 155. Vacant .....	42
<b>SECTION L—SETTLEMENT FOR DESTROYED, BADLY DAMAGED, OR</b>	

## AAR Intermodal Interchange Rules

---

<b>STOLEN UNITS—HANDLING CARRIER RESPONSIBILITY .....</b>	<b>43</b>
156. Destroyed, Badly Damaged, or Stolen Units .....	43
a. Notification, Depreciated Value, and Disposition .....	43
b. Repair Costs Over Limit.....	43
c. Salvage Value .....	50
157. Handling Line Repair .....	50
158. Units Requested Home for Repairs .....	50
159. Vacant.....	50
160. to 164. Vacant .....	50
<b>SECTION M—SETTLEMENT FOR DEFECTIVE UNITS—OWNER’S RESPONSIBILITY.....</b>	<b>51</b>
165. Notification/Authorization .....	51
166. Disposition .....	51
a. Return Home .....	51
(1) Dispute .....	51
b. Disposal .....	51
167. to 170. Vacant .....	51
<b>SECTION N—LOCATIONS AND STENCILING.....</b>	<b>53</b>
171. Location Designations .....	53
a. Front/Rear.....	53
b. Sides and Top .....	53
c. Tires and Axles.....	53
172. Stenciling—Weight, Height, Capacity .....	54
a. Alteration of Stencils .....	54
b. Included in Empty Weight .....	54
173. Reporting Marks and Numbers .....	56
a. Trailers or Containers .....	56
b. Chassis .....	56
c. Non-Satisfactory Markings.....	56
d. Short Term Leasing.....	57
e. Change in Status .....	57
174. Hazardous Placards.....	57
175. Vacant.....	57
176. to 179. Vacant .....	57
<b>SECTION O—CONDITIONS OF ACCEPTANCE.....</b>	<b>59</b>
180. Vacant.....	59
181. Acceptance of Rules .....	59
<b>SECTION P—SUBSCRIPTION TO THE <i>INTERMODAL INTERCHANGE RULES</i>.....</b>	<b>61</b>
182. Notification .....	61
183. Subscription .....	61
184. Availability .....	61
<b>SECTION Q—PROPOSED CHANGES TO AAR <i>INTERMODAL INTERCHANGE RULES</i> .....</b>	<b>63</b>
185. Procedure for Proposing Changes.....	63

# AAR Intermodal Interchange Rules

---

<b>APPENDIX A—BILLING PROCEDURES .....</b>	<b>65</b>
A1. Required Documents .....	65
a. Form J-2 .....	65
b. FMCSA Inspections .....	65
A2. Repair Records .....	65
a. Generation and Retention .....	65
b. Required Information .....	65
A3. Billing Categories .....	65
A4. Billing Formats .....	66
A5. Mechanized Billing .....	66
d. Required Information: .....	66
A6. Vacant .....	67
A7. Exceptions .....	67
A8. No Bills .....	67
A9. Handling of Bills .....	68
a. Calculation Date of Charges .....	68
b. Owner Responsibility .....	68
c. J-2 Repairs .....	68
d. Consolidation of Charges .....	68
e. Time Limits .....	68
f. Corrections .....	68
g. Units Retired vs. Repaired .....	68
A10. Condition, Why Made, Responsibility, and Location Codes .....	69
A11. Organization of Job Codes .....	71
a. 1000–1999—Tires/Rims .....	71
b. 2000–2799—Suspension and Tandems .....	71
c. 2800–2999—Air Ride .....	71
d. 3000–3999—Unders Construction—Below Floor, Except Tandem .....	71
e. 4000–4999—Body Construction .....	71
f. 5000–5099—Chassis Frame .....	71
g. 5100–5299—Chassis Rack .....	71
h. 5300–5399—Containers .....	71
i. 5400–5899—Miscellaneous .....	71
(1) 5400 - 5700 Misc. .....	71
(2) 5701 - 5709 DVIR Inspections .....	71
(3) 5710 - 5899 Misc. .....	71
j. 5900–5999—Vacant .....	71
k. 6000–6299—Mechanical Refrigeration/Heater Units .....	71
l. 6300–6499—Vacant .....	71
m. 6500–6799—Tank Containers .....	71
n. 6800–6990—Vacant .....	71
o. 6991–6999—Taxes .....	71
p. 7000–7999—Reserved for Expansion .....	71
q. 8000–9999—Reserved for Individual Railroads .....	71
<b>APPENDIX B—CORRECT UNIT REPAIR PROCEDURES .....</b>	<b>75</b>
B1. Introduction .....	75



## AAR Intermodal Interchange Rules

---

a.	Preface .....	75
b.	Proper Repairs.....	75
c.	Equipment Component Compatibility.....	75
d.	Owner's Requirements .....	75
e.	Tamper Evidence Requirement .....	75
B2.	General Trailer/Container Repairs .....	76
a.	Post and Panel Damage .....	76
b.	Joining Dissimilar Materials .....	76
(1)	Joining Aluminum to Unfinished Steel or Stainless Steel .....	76
(2)	Joining Aluminum and Wood Components.....	76
B3.	Body Repairs (Side Panels).....	77
a.	Mating of Panels .....	77
b.	Repairing Body Panels of Sheet and Post Trailers and Containers .....	77
c.	Repairing Body Panel of Steel Container .....	78
(1)	Straightening .....	78
(2)	Straightening and Welding.....	78
(3)	Inserting.....	79
d.	Overlay .....	80
e.	Panel Replacement of Sheet and Post Trailers and Containers.....	80
f.	Panel Assembly (Multiple Panels) Replacement .....	81
B4.	Floors.....	82
a.	Floor Structure and Damage .....	82
b.	General Repairs.....	83
c.	Types of Repair (from Least to Most Aggressiveness) .....	84
(1)	Cleaning .....	84
(2)	Secure .....	84
(3)	Dowel Repairs .....	84
(4)	Sectioning or Partial Replacement—Plank Floor .....	85
(5)	Sectioning or Partial Replacement—Plywood Floor.....	85
(6)	Complete Replacement—Plank Floor .....	86
(7)	Complete Replacement—Plywood Floor.....	86
d.	Side Liners.....	86
e.	Scuff Liner.....	86
f.	Roof.....	86
B5.	Trailer or Chassis Support Repairs.....	86
a.	Landing Legs .....	86
(1)	Description.....	86
(2)	Defects .....	88
(3)	Repair Comparability Required .....	88
(4)	Component Replacement vs. Leg Replacement .....	89
(5)	Landing Gear Mounting Bracket.....	89
(6)	Sand Shoes, Dolly Wheels, and Axles .....	89
(7)	Landing Gear Crank Handle.....	89
(8)	Cross Shaft.....	89
B6.	Roof Repairs.....	89
a.	General Repairs.....	89
b.	Roof Patching—Aluminum.....	91

## AAR Intermodal Interchange Rules

---

c. Roof Sheet Breaks More than 6 in.....	91
d. Roof Replacement—Aluminum .....	92
e. Roof Bows .....	92
f. Corrugated Steel Roof.....	92
B7. General Repair Policy for Corner Posts.....	94
B8. Rear Doors and Rear Frame .....	97
a. General.....	97
b. Repair Procedures.....	99
(1) Rear Doors .....	99
(2) Security Hardware .....	99
(3) Rear Door Frame.....	100
B9. Splicing of Side Rails.....	100
a. Repair Procedures.....	100
b. Aluminum Trailers.....	100
c. Aluminum Containers.....	102
d. Steel Containers .....	103
e. Definitions .....	106
(1) Top Rail Protectors .....	106
(2) Lift Pads (Bottom Rail Protectors) .....	106
B10. Riveting.....	108
a. General.....	108
b. Inspection Procedures for Locating Defective or Loose Rivets .....	108
c. Proper Riveting Procedures.....	109
(2) Tools .....	109
B11. Axles, Bearings, and Brakes.....	113
a. General.....	113
b. Brakes.....	113
(1) Brake Inspection.....	113
(2) Brake Adjustments .....	113
(3) Spring Brake Chambers .....	114
(4) Brake Liners .....	114
B12. Upper Coupler and Kingpin .....	118
a. Kingpin.....	118
(1) Repair Restriction.....	118
(2) Kingpin Wear Limits.....	118
b. Upper Coupler .....	119
B13. Subassembly .....	124
a. Locking Mechanisms .....	124
(1) Types.....	124
(2) Safety Requirement.....	124
b. Guide and Hold-Down Brackets .....	124
c. Maintenance .....	124
d. Air Rides .....	125
B14. Electrical and Air Systems .....	128
a. Electrical System .....	128
(1) Lighting System.....	128
(2) Protective Coating .....	128

# AAR Intermodal Interchange Rules

---

(3) Welding.....	128
b. Air System .....	129
(1) Air Relay Valve Replacement .....	129
(2) Drain Cock Manual Replacement.....	129
(3) Glad Hand Placement .....	129
B15. Tires .....	132
a. Safety Precautions.....	132
b. Inflation .....	133
c. Vacant .....	133
d. Vacant.....	133
B16. DOT Underride Guard.....	133
<b>APPENDIX C—GLOSSARY .....</b>	<b>135</b>
C1. General Terms .....	135
C2. Trailer Component Glossary .....	135
C3. Container Component Glossary.....	139
C4. Tire Glossary.....	141
<b>APPENDIX D—FLAT FILE FORMAT.....</b>	<b>149</b>
D1. Introduction .....	149
D2. J File Format.....	149
D3. J2 Format.....	149
a. Header Fields .....	149
b. Line Item Fields .....	150
D4. Reading The File.....	150
<b>APPENDIX E—SUBSCRIBERS TO THE INTERMODAL INTERCHANGE AGREEMENT ....</b>	<b>151</b>
E1. Railroad Companies .....	151
E2. Non-Railroad Companies.....	152
<b>APPENDIX F—COMPLETE MATRIX.....</b>	<b>153</b>
<b>APPENDIX G—ASSOCIATION TABLE.....</b>	<b>155</b>

## AAR Intermodal Interchange Rules

---

THIS PAGE LEFT BLANK INTENTIONALLY

# AAR Intermodal Interchange Rules

## List of Figures

Figure 1 — 7-Way Receptacle.....	2
Figure 2 — Form J-1—Unit Interchange and Safety Inspection Form .....	32
Figure 3 — Form J-2—Intermodal Equipment Damage Form.....	33
Figure 4 — Vacant.....	34
Figure 5 — Form J-3—Authority for Transfer or Adjustment of Intermodal Equipment or Intermodal Lading .....	35
Figure 6 — Vacant.....	36
Figure 7 — Form J-5—Counterbilling Authority.....	37
Figure 8 — Form J-6—Federal Motor Carrier Safety Administration (FMCSA) Periodic Inspection (Sample).....	38
Figure 9 — Form J-7 (Sample).....	39
Figure 10 — Quad Axle Diagram.....	55
Figure 11 — Tri- and Double-Axle Diagram.....	55
Figure 12 — Axle Diagram (Side).....	56
Figure 13 — Placement of hazardous placards .....	57
Figure 14 — Association of American Railroads Unit Repair Billing Form .....	72
Figure 15 — Association of American Railroads Tire Repair Billing Form.....	73
Figure B-1 — Patching Panels .....	77
Figure B-1a — Patching Panels .....	78
Figure B-2 — Panel Insert .....	79
Figure B-3 — Panel Overlay.....	80
Figure B-4 — Floor Repairs.....	83
Figure B-5 — Leg Assembly, Driver .....	87
Figure B-6 — Support Frames and Supports .....	88
Figure B-7 — Roof Sheet Edge Treatment.....	90
Figure B-8 — Improper Repairs to Corner Posts .....	95
Figure B-9 — Correct Repairs to Corner Posts .....	96
Figure B-10 — Rear Door Assembly .....	97
Figure B-11 — Rear Frame Assembly .....	98
Figure B-12 — “Rule of Thumb” for Trailer Splicing .....	101
Figure B-13 — Splicing Bottom and Top Rails .....	102
Figure B-14 — Not Acceptable and Acceptable Rails .....	104
Figure B-15 — Acceptable Bottom Rail Inserts .....	105
Figure B-15a — Trailer Lift Pads (Bottom Rail Protectors).....	106
Figure B-16 — Splicing of Top Rails.....	107
Figure B-17 — Splicing of Bottom Rails .....	108
Figure B-18 — Proper Rivet Length .....	109
Figure B-19 — Good and Bad Rivet Heads .....	111
Figure B-20 — Solid Rivet Chart — Sizes and Ratings.....	112
Figure B-21 — Axle Assembly.....	115
Figure B-22 — Axle/Brake Assembly .....	116
Figure B-22a — Acceptable and Unacceptable Cracks in Shoes .....	117
Figure B-23 — Kingpin Wear Limits .....	120
Figure B-24 — Kingpin Nicks, Burrs, Gouges .....	120
Figure B-25 — Inspection of Kingpin Diameters Using One Type of Gauge.....	121
Figure B-26 — Kingpin Length and Squareness Check Using One Type of Gauge .....	122

## AAR Intermodal Interchange Rules

---

Figure B-27 — Front Frame .....	122
Figure B-28 — Floorbed and Frame Assembly .....	123
Figure B-29 — Subframe Assembly, Lower—FS Slider .....	126
Figure B-30 — Spring Assembly .....	127
Figure B-31 — Air Connections.....	130
Figure B-32 — Air Actuation Brake System .....	131
Figure C-1 — Trailer Components—Front/Side .....	145
Figure C-2 — Trailer Components—Rear .....	146
Figure C-3 — Retread Casing—Tubeless Type .....	147
Figure C-4 — Buffed Casing—Bias Tubed Type.....	148

# AAR Intermodal Interchange Rules

---

## PREAMBLE

The latest published edition of the Intermodal Interchange Rules shall supersede any previous editions, updates, circulars, actions, publications and/or dockets intended for inclusion in and/or relating to the Intermodal Interchange Rules

## PREFACE

The rules contained herein do not foreclose AAR members from entering into other agreements which may be contrary to these rules.

These rules are formulated to provide a means for fair and proper adjustments of questions arising between unit owners and handling companies, with the intent of:

- Making the unit owner responsible for, and therefore chargeable with, repairs to its units, necessitated by ordinary wear and tear in fair service, by safety requirements, by the standards of the Association of American Railroads, and by the requirements of the various regulatory agencies controlling highway movement of such equipment.
- Placing responsibility and providing a means of settlement for damage to any unit occurring through improper handling or improper protection by the handling company.
- Providing that inspection of unit for interchange will be in accordance with the Code of Rules.
- Assuring that settlement of disputes occurring under other arrangements not invoking these Rules must be settled in accordance with the terms of the agreement or contract between the parties involved.

AAR members agree to accept equipment that is in compliance with these rules, and may accept other equipment at their individual discretion.

Where the term "units" appears in these rules, it includes all equipment which is designed for use in TOFC/COFC Service, including trailers, containers, and chassis, as defined in Rule 159.

Where the term "owner" appears in these rules, it shall be interpreted to include "lessee," but in any case will be the owner or lessee of record as identified on unit.

Where the term "handling line," or "handling carrier," appears in these rules, it applies to the carrier in possession of the unit.

Where the term "originating carrier" appears in these rules, it applies to the carrier on which the unit originates.

Where the term "delivering carrier" appears in these rules, it applies to the carrier, which offers the unit to another carrier in interchange, at the point of interchange.

Where the term "receiving carrier" appears in these rules, it applies to the carrier, which accepts the unit from another carrier in interchange, at the point of interchange.

Where reference to physical documents is made, electronic versions thereof may be substituted by mutual agreement.

## AAR Intermodal Interchange Rules

---

THIS PAGE LEFT BLANK INTENTIONALLY



# AAR Intermodal Interchange Rules

## SECTION A

### GENERAL CONDITIONS GOVERNING ACCEPTANCE AND DELIVERY OF UNITS IN INTERCHANGE

#### 1. Equipment Specifications

All units shall conform to applicable AAR or ISO Specifications (See AAR Intermodal Standards M-930, M-931, and M-962. Units not in conformance with AAR or ISO Specifications in effect as of the date of manufacture may be refused in interchange service.

Should a conflict arise between the AAR and ISO specifications, the AAR specification will take precedence.

#### 2. Hazmat Placarding

Trailers and containers containing hazardous materials shall be properly placarded in accordance with the Hazardous Materials Regulations of the Department of Transportation and such other regulations governing safe transportation.

No surface material of previous placards is acceptable in interchange. Painted-over placards are not acceptable.

#### 3. Loading Practices

- a. Lading shall be properly distributed, secured and blocked, and in compliance with the *AAR Intermodal Loading Guide for Products in Closed Trailers and Containers* and the *AAR Open Top Loading Rules Manual, Section 7, "Rules for Loading All Commodities on Open Top Trailers/Containers for Rail Transport."* It is not intended that closed trailers or containers be opened for interior inspection of loads unless the trailer or container shows exterior evidence of distress, apparently due to lading conditions, or unless there is reason to believe that the trailer or container has not been properly loaded.
- b. Loading of units on rail cars shall be in compliance with the AAR Intermodal Committee *Loading Capabilities Guide*, available on the AAR website ([www.aar.org](http://www.aar.org)).

#### 4. Clearance Profile

Units shall conform to published railroad clearances to final destination and to published highway clearances where units are handled off-rail.

#### 5. Weight Restrictions

The weight of the unit and lading shall conform to all regulations governing the various transportation services to final destination.

# AAR Intermodal Interchange Rules

## 6. 7-Way Receptacle

Trailers and chassis shall be equipped with a conventional (7 conductor) electrical connector socket, wired and installed as shown in **Figure 1**. The voltage marking shall be shown adjacent to the socket in not less than 1-in.-high letters, only if it is different than 12 volts.

**Figure 1 7-Way Receptacle**

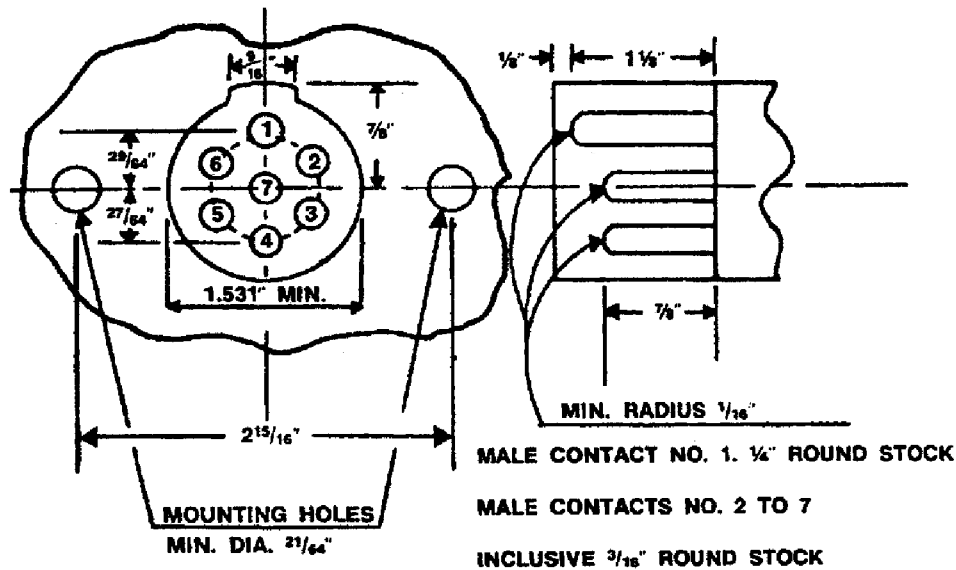

Conductor Number	Wire Color	Lamp and Signal Circuits
1	White	Ground return to towing vehicle
2	Black	DOT-required marker and clearance lamps
3	Yellow	Left-hand directional signal
4	Red	Stop lamps and anti-lock devices
5	Green	Right-hand directional signal
6	Brown	Tail lamps, three-bar marker lamps, and clearance or marker lamps other than DOT-required
7	Blue	Anti-lock brake system.

The standard receptacle shall be constructed as a flush-mounted unit and provided with a cover, and shall be mechanically attached to the 7-way receptacle base. Cover shall make the 7-way receptacle weather tight when the cable plug is not inserted.

# AAR Intermodal Interchange Rules

## 7. Lights

- a. Trailers and chassis shall be equipped with properly operating stop lights, tail lights, flashing turn signals, clearance and marker lights, reflectors, and other parts and accessories as required by governmental regulatory agencies.
- b. Units shall be equipped with conspicuity tape as required by governmental regulatory agencies. Chassis also shall have conspicuity tape applied to the front bolster.

## 8. Tank Containers

Tank containers must comply with applicable Department of Transportation regulations.

### a. General

#### (1) Compliance Certification

TOFC loading of tank containers must be on certified AAR M-931 Appendix G chassis.

#### (2) Loading Conditions

Tank containers must comply with applicable DOT regulations, including 49 CFR 174, for interchange movement under these rules. Additionally, on conventional single-unit COFC cars, end-of-car cushioning and positive lock securement devices meeting the requirements of AAR Specification M-952, latest revision, are required. Cushioning protection is not required on multi-unit spine cars and other slackless intermodal equipment. Tank containers may be moved in the well of single- or multi-unit double-stack cars, but no other container may be loaded above the tank container placarded "Hazmat." In single- or multi-unit double-stack cars, neither cushioning nor positive lock securement is required.

#### (3) Tank Data Plate

Tank data plate(s) must be affixed to the tank or frame.

#### (4) Tank and Safety Relief Valve

Tank and safety relief valve, if installed, must have a retest interval no greater than 5 years. Retest and test due dates must be marked or stenciled on the tank or on an appropriate plate.

#### (5) Inspection

Tank containers must be inspected for leakage before acceptance for shipment.

### b. Interchange of 40 ft Tank Containers

The following interchange requirements apply to 40 ft. tank containers:

- (1) Tank must be placed in bottom position of well car.
- (2) Tank *cannot* be shipped TOFC.

# AAR Intermodal Interchange Rules

- (3) Tank must be greater than 80% full or less than 20% full.
- (4) Speed-restricted commodities are *not* acceptable.
- (5) Double-stacking of hazardous or hazardous-residue tank containers is *prohibited*.
- (6) Hazardous commodities must be in a 40 ft well car.
- (7) Placing a dry or non-hazardous container on a non-hazardous ISO tank is permitted.

## 9. Tank Trailers (“Cargo Tanks”) Carrying Materials

Tank trailers carrying hazardous materials are **prohibited** in TOFC service, except AAR M-931 specification tank trailers as may be allowed by Department of Transportation regulation.

## 10. Registration/Permit Holder

A waterproof container for necessary papers and documents to accompany the trailer shall be attached to the exterior of the trailer, on the nose end, as near the side and bottom of the trailer as practical. The same type container shall be attached to the main rail of the chassis near the VIN plate.

## 11. Tires

Trailers and chassis shall be equipped with tires conforming to requirements of Section B of these rules.

## 12. Landing Gear

Trailers and chassis shall be equipped with landing gear conforming to requirements of Section C of these rules.

## 13. Licensing

Trailers and chassis shall be equipped with valid license plates of the state of registry. It is the responsibility of the originating carrier to ensure that trailers and chassis are properly licensed and registered.

## 14. Interchange Placement

A unit offered in interchange shall be considered as accepted by the receiving carrier.

### a. Rail Interchange

When the car with the unit is placed on a track agreed upon and designated as the interchange track for such delivery, and is accompanied or preceded by proper data for forwarding and to ensure delivery.

### b. Rubber Interchange

When a unit that is interchanged by street or highway with through waybill and is placed in a yard or at a point agreed upon and designated as the interchange point for such delivery, accompanied or preceded by proper data for forwarding and to ensure delivery, and unit inspection form or recorded image completed.

# AAR Intermodal Interchange Rules

## 15. Defective Units

A unit offered in interchange with defects as defined in Section F may be rejected by the receiving carrier.

## 16. Flat Rack Containers

The following interchange requirements apply to AAR-approved versions (versions 6.2 and 7.1) of Raildecks flat rack containers:

### a. Concentrated Loads

Raildecks version 6.2 or 7.1 are limited to hauling concentrated loads that do not exceed 46,000 lb. Concentrated loads are defined as the total load weight acting in 4 linear feet or less of the deck. Concentrated loads shall be placed in the bottom position of a double-stack well car that is capable of handling 20 ft containers.

### b. Well Placement

Loaded Raildecks must be placed in the bottom position of all well cars. Empty Raildecks can be placed in top position in double-stack or bottom position in single-stack configuration as long as the center of gravity is taken into account.

### c. Loaded Stacking Configuration

The gross weight of the top container in any double-stack configuration cannot exceed the gross weight of the bottom container. Exception: CN will only accept in single-stack configuration.

### d. Steel Coils

Steel coils are permitted in interchange provided that the originating and receiving railroads have both approved the shipper.

### e. Load Securement

All load securement meets or exceeds securement standards set forth by the AAR Open Top Loading Rules (OTLR) committee.

### f. Gross Weight

Gross weight (Net + Tare) of the Raildeck container and lading shall not exceed 67,200 lb.

### g. Hazmat Restrictions

No placarded HAZMAT containers may be loaded in the same well with the Raildeck container or in any adjacent well.

### h. Empty Collapsed Movement Requirements

Empty bundled Raildecks stacked three or four high with arms collapsed are acceptable in interchange.

# AAR Intermodal Interchange Rules

## 17. Gasoline/LPG Refrigeration Units

Trailers or containers using gasoline or liquefied petroleum gas to operate refrigeration units must be permanently stenciled, "Gasoline Driven Refrigeration Unit" or "Liquefied Petroleum Driven Refrigeration Unit" in accordance with Section D, Rule 55 of these rules.

## 18. Portable Heater Units

Trailer/container equipment with portable heating units may be refused in interchange service.

## 19. Equipment Registration and Reporting

### a. Equipment Initial/Number

Each unit shall have an assigned reporting mark of its owner or lessee and the number of the unit appearing thereon, as provided in Rule 173.

### b. TRAIN II and UMLER Reporting

Effective July 1, 1999, to facilitate tracking and accounting of equipment, equipment owners shall register all trailers, containers, and chassis in the Universal Machine Language Equipment Register (UMLER), as specified in the *UMLER Specification Manual*.

Effective July 1, 1999, to facilitate tracking and accounting of equipment, handling lines shall report all trailer, container, and chassis interchanges and movements to TRAIN II, as specified in the *TRAIN II User's Manual*.

Where the term "unit" appears in these rules, it includes all railroad-owned and private equipment that is used in intermodal service.

## 20. Kingpin Wear Limits

Trailers and chassis offered in interchange may be refused by the receiving carrier if wear limits exceed those prescribed by SAE J-2228, latest revision [see Appendix B, Section B12(a)].

# AAR Intermodal Interchange Rules

## 21. 53 ft Chassis Shipping Units

The following interchange requirements apply to AAR-approved chassis shipping unit(s) (CSU):

### a. Definitions

- (1) Loaded—at least one chassis resting on a CSU
- (2) Stacked—multiple chassis stacking units secured together
- (3) Empty CSU—a single unit, not collapsed, no chassis resting in it

### b. Well Placement

Stacked CSUs are accepted only in single-stack configuration and must be placed in the bottom position of all well cars. Loaded CSUs may be placed in top position in double-stack as long as the center of gravity is taken into account; or in bottom position in single-stack configuration. CSUs may be placed in the upper position of a 40 ft well car. CSUs may be placed on top of two adjacent 20 ft containers in the same well.

A loaded CSU cannot be placed in bottom position (due to bolster overhang). Loaded CSUs may be placed only in top position on a double-stack well car. Stacked CSUs may be bottom placed. Nothing may be placed on top of a loaded CSU, a stacked CSU, or an empty CSU.

For 53 ft CSUs: Do not place any 53 ft loaded CSU in the bottom position. It must be placed in top position on double-stack well car due to bolster overhang. An empty or a stacked CSU may be loaded either in the top position or in the bottom position with nothing placed on top.

For 40 ft CSUs: May place a 40 ft loaded CSU only in the bottom position of a 45 ft or longer double-stack well car. For a 40 ft double-stack well car, a 40 ft loaded CSU must be placed only in top position due to bolster overhang. An empty or a stacked CSU may be loaded either in the top position or in the bottom position with nothing placed on top.

### c. Weight Consideration

The gross weight of a loaded CSU in the top position of any double-stack configuration cannot exceed the gross weight of the bottom container.

### d. Load Securement

All load securement meets or exceeds securement standards set forth by the AAR Open Top Loading Rules (OTLR) committee. Stacked CSUs must face the same direction.

## AAR Intermodal Interchange Rules

### **e. Gross Weight**

Gross weight (net + tare) of the 53 ft and 40 ft CSU, loaded or stacked, shall not exceed 67,200 lb.

Gross weight (net + tare) of the 20 ft CSU, loaded or stacked, shall not exceed 52,900 lb.

All loaded or stacked CSUs shall not exceed 9 ft 6 in. in height.

### **f. Stacked Movement Requirements**

Stacked CSUs, four high or fewer with stanchions collapsed, are acceptable in interchange.

Stacked CSUs shall not exceed 9 ft 6 in. in height.

**22. to 25. Vacant**



# AAR Intermodal Interchange Rules

## SECTION B

### TIRES AND TUBES

#### 26. Conditions at Time of Acceptance and in Interchange

The following are conditions at time of acceptance and in interchange.

##### a. Presence of Tires and Wheel Lugs

Tires and all wheel lugs must be in place on all wheels in service.

##### b. Suitability of Tires and Rims

Tires and rims must be in suitable condition for safe movement to final destination and must conform to requirements of governmental regulatory agencies.

##### c. Tire Markings

At the time of inspection, the company tire brand, if any, or manufacturer's serial number and tire size must be in evidence.

##### d. Lack of Foreign Objects

Tires must be free of visible foreign objects such as nails, etc., imbedded in or protruding from tire, as well as defects listed in Rule 27.

##### e. Inflation and Mating

Tires must be properly inflated and mated by physical size (e.g., R22.5) on the same axle.

#### 27. Maintenance, Repair, and Replacement

##### a. Trailer or Chassis Owner Responsibility

Repairs, renewals, or replacement of tires and/or tubes shall be at the expense of the trailer or chassis owner, except as otherwise provided in Section F. The trailer or chassis owner shall be responsible for renewal of tires and tubes when necessary, due to the following causes:

- (1) Tread depth 2/32 in. or less. Measurement must be made in tread grooves only, not to include tire tread tie bars.
- (2) Separation of tread
- (3) Visible blisters or knots
- (4) Worn out, deteriorated tube
- (5) Pulled valve stem, cut tube, when not associated with Section F damage to tire

# AAR Intermodal Interchange Rules

## b. Handling Line Responsibility

### (1) Maintenance

The carrier in possession of a trailer or chassis in interchange service shall provide maintenance to tires and tubes, including proper inflation, the repair of flat tires, pulled valve stems, etc., subject to provisions of other rules with regard to charges. When a tire and/or tube is repaired or replaced, the carrier in possession must inflate all tires on the trailer or chassis to the manufacturer's recommended psi. Ensure all hoses are reconnected to automatic tire inflation systems. Valve caps must be installed.

### (2) Unserviceable Tires

When an unserviceable tire is replaced by other than the owner, it must be with a new tire or newly recapped tire meeting the Minimum Standard for Retreading and Repairing Bias Ply and Radial Tires, as shown in [Appendix B, Section B15](#) to justify charge to the owner. The application of used tires and/or tubes by the handling carrier is prohibited and is considered wrong repair, and no charge can be assessed the trailer or chassis owner.

### (3) Rims

Exchanging of rims is prohibited, unless necessary due to an unserviceable rim. When replacing a rim, a rim of the same type and size must be used, e.g., 20 in. tube type with a 20 in. tube type; 22 in. tubeless with a 22 in. tubeless.

### (4) Serviceable Tubes

When a tire is replaced, a serviceable tube and flap that is removed must be reapplied.

### (5) Unserviceable Tubes

When an unserviceable tube is replaced by other than the owner, the tube must be replaced with a new tube to justify charge. The unit repair billing form must show the size, the location on/off, and the reason for replacement.

### (6) Booting, Sectioning, or Vulcanizing

Structural repairs to tires on foreign trailers or chassis by booting, sectioning, or vulcanizing by the handling carrier is prohibited and is considered wrong repair, and no charge can be assessed the trailer or chassis owner.

### (7) Exchanging of Tires

Exchanging or swapping tires due to a flat tire condition is prohibited.

### (8) Multiple Renewals and Replacement at Terminals and by Contracted Vendors

Renewals and replacements at terminals and by contracted vendors of two or more tires on the same unit due to the causes listed as Trailer or Chassis Owner Responsibility ([Rule 27a](#)) require fax or electronic notification to the owner within 2 business days from the time of repair, if the owner has provided notification information for the listing published by the AAR. Lack of receipt of required notification by an owner is not in itself justification for not paying a repair bill.

## AAR Intermodal Interchange Rules

### **c. Repair, Renewal, and Replacement Procedures**

#### **(1) Tire Repair Billing Form**

The Tire Repair Billing Form to the owner must show the tire size and manufacturer's DOT tire identification number for each new tire applied or the recapper's DOT tire identification number for each recapped tire applied to justify charge. The same information must also be shown for each tire removed, if available. Billing must also show tire location and the reason for replacement to justify charge. All information pertaining to DOT identification codes, both on new or recap tires, must follow federal regulations, in accordance with Tire Identification and Recordkeeping Regulation, 49 CFR Part 574 (36 FR 1197).

#### **(2) Inspection and Collection of Unserviceable Tires**

The inspection and collection of unserviceable tire(s) shall be a matter of mutual agreement between involved parties as to procedures.

### **d. Retention Period for All Removed Tires (Including Section F Damage)**

When tires are removed from a trailer or chassis at an intermodal facility or at an outside repair facility authorized by the railroad, the tire must be maintained at the facility for at least 3 days excluding holidays and weekends or as otherwise agreed. Tire(s) must be marked identifying the trailer or chassis initial and number, date, wheel position, and circle defect. The Why Made Code and tread depth must also be indicated.

### **28. to 40. Vacant**

# AAR Intermodal Interchange Rules

THIS PAGE LEFT BLANK INTENTIONALLY

**SECTION C**

**LANDING GEARS**

**41. Conditions at Time of Acceptance and in Interchange**

The following are conditions at time of acceptance and in interchange:

**a. Load Support**

The landing gear must be in suitable condition to properly support the trailer or chassis load.

**b. Condition and Securement**

The landing gear must be properly secured to trailer or chassis, complete as to component parts, and in satisfactory operating condition.

**c. Clearances**

The landing gear of the trailer or chassis while loaded on a railcar must clear the car floor and other fixed obstructions at all times by not less than 4 in. to prevent damage.

**42. Maintenance and Operation**

**a. Maintenance, Repairs, and Lubrication**

The carrier in possession of the trailer or chassis shall provide good maintenance to the landing gear, including minor repairs and lubrication.

**b. Raising Landing Gear**

The landing gear must be raised sufficiently above the car floor or ground before moving the trailer or chassis, to prevent damage.

**c. Lowering Landing Gear**

The trailer or chassis landing gear must be properly lowered before disconnecting the tractor from the trailer or chassis.

**43. to 54. Vacant**

# AAR Intermodal Interchange Rules

THIS PAGE LEFT BLANK INTENTIONALLY

**SECTION D**

**REFRIGERATION AND HEATING**

**55. Conditions at Time of Acceptance and in Interchange for Mechanical Units**

The following are conditions at time of acceptance and in interchange:

**a. Stenciling/Fuel type**

Trailers or containers equipped with mechanical units shall be stenciled in letters not less than 1 in. high to indicate the type of fuel used to drive the unit and the capacity of the fuel tank. Stenciling shall be located adjacent to the unit or fuel tank filler cap. The type of fuel used for operating the mechanical unit is subject to the restrictions provided in Section A, Rule 17.

**b. Satisfactory Operating Condition**

At the time of interchange of a loaded trailer or container under heat or refrigeration, the mechanical unit shall be in satisfactory operating condition. Where evidence indicates a defective mechanical unit or improper inside air temperature, the trailer or container may be refused in interchange.

**c. Sufficient Oil and fuel**

At the time of interchange of a loaded trailer or container under heat or refrigeration, the mechanical unit shall have sufficient oil and fuel to ensure 24 hours' continuous operation.

**56. Vacant**

**57. Maintenance**

The carrier in possession of the trailer or container shall provide proper maintenance to the heating and/or refrigeration unit, including any immediate repair necessary to maintain lading protection. The cost of repairs made as a result of such maintenance may be billed against the owner, except that fuel applied is at no expense to the owner.

**58. Portable Units**

Trailer/container equipment with portable units may be refused in interchange service.

**59. to 70. Vacant**

# AAR Intermodal Interchange Rules

THIS PAGE LEFT BLANK INTENTIONALLY



## SECTION E

### ACCESSORIES AND SPECIAL EQUIPMENT

#### 71. Removable Items/Stenciling

The name and number of removable items accompanying open top, platform, or flatbed trailers must be stenciled in not less than 1 in. figures in a suitable location of the trailer (preferably the front portion of the bulkhead).

Removable items include:

- a. Chains, binders, cables and tie-down devices
- b. Tarpaulins, including securements
- c. Tarpaulin bows
- d. Rear header bar (high-side open top)
- e. Bulkhead

#### 72. Delivering Carrier Responsibility

The delivering carrier shall be responsible for any removable items listed in Rule 71, and so stenciled on trailer, that are missing when the trailer is offered in interchange.

#### 73. Handling Carrier Responsibility

##### a. Securement of Equipment

The proper replacement and securement on the trailer of tarpaulins, tarpaulin bows, rear header bar, side sections, end gates, etc., that were removed to facilitate loading or unloading is the responsibility of the carrier in possession of the trailer.

##### b. Tarpaulins and Bows—Loaded Trailers

When a loaded open top trailer is offered in interchange and is equipped with tarpaulins and bows, the tarpaulin and bows must be in their proper position with the tarpaulin spread and secured.

In the event the lading is of such nature that the tarpaulin and bows cannot be applied, they must be placed in the proper storage receptacle where the trailer is so equipped or accompany the load, if possible. If the equipment cannot be forwarded in either manner, provision should be made to ship same to the trailer owner, properly identified, at the expense of the carrier returning the equipment.

## AAR Intermodal Interchange Rules

### **c. Equipment—Empty Trailers**

When an empty open top or platform type trailer is offered in interchange and is equipped with tarpaulin and bows, side and end gates, etc., the tarpaulin and bows, side and end gates, etc., must be in proper place and secured on the trailer or placed in the proper storage receptacle (where the trailer is so equipped) or be secured to the headboard or deck of the trailer.

When side and end gates are in an upright position on the trailer, the bows must also be in proper position, and the tarpaulin must be properly stored.

Chains, binders, cables, and tie-downs devices must not be laced or allowed to hang over rub rails of flatbed trailers.

**74. to 80. Vacant**

# AAR Intermodal Interchange Rules

## SECTION F

### HANDLING CARRIER RESPONSIBILITY

#### 81. Damage—By Causes

Handling carriers are responsible for damage caused by:

- a. Accident of any type, at any time, on or off a railcar
- b. Storm or flood
- c. Explosion
- d. Unconcealed fire and inside or concealed fire, when handling line has knowledge of same, while unit is in its possession
- e. Vacant
- f. Failure to properly close and secure doors
- g. Contamination by loading with contaminating commodities such as odors, penetrating stains, and/or residue.
  - (1) Trailers or containers must not be loaded with contaminating commodities unless the trailer or container is stenciled by the owner "Contaminate Loading Only" on the front of the vehicle in not less than 4 in. letters or as otherwise specifically authorized by owner.
  - (2) Where the handling carrier is not responsible for a contaminating loading, it shall furnish information on the Unit Interchange and Safety Inspection Report, Form J-1, to indicate the originating carrier, who shall be responsible to the owner for reconditioning of the trailer or container.
- h. Repair and servicing to brakes and brake system components due to accumulation of ice and snow

#### 82. Damage—Evidential

Handling carriers are responsible for damage as follows:

- a. Metal door, gate, sheet, post, crossmember, brace, or support cut or torn through thickness of metal, including such cuts or tears covered by tape, caulk, and/or tar
- b. Metal door, gate, sheet, post, crossmember, brace, or support bent, where proper operation or function of unit is impaired, except when caused by deterioration due to corrosion or decay
- c. Clean Interior
- d. DOT Under Ride Guard missing or damaged per Appendix B, Section B16
- e. Tire sidewall cut/punctured, exposing belt material

## AAR Intermodal Interchange Rules

- f. Tire shoulder and/or tread cut/punctured, exposing belt material, when such injury is larger than 1/4 in. When the tire shoulder and/or tread is punctured through the tire, causing a hole 1/4 in. in diameter or less, the injury must be patched prior to reuse.

### g. Tires Slid Flat

#### (1) Replacement

Damage to tires and tubes as a result of being slid flat. Any tire is considered to be “slid flat” if a flat spot occurs and removes tread or rubber to 2/32 in. of remaining tread or less in the affected area (flat spot) while the remaining unaffected tread is more than 4/32 in. It is not necessary for the tire to have a loss of air. Any tire with more than 2/32 in. of tread remaining at all locations does not require replacement.

#### (2) Repair

Tires on the same wheel set that have a flat spot occur that removes 6/32 in. of tread or rubber (when compared to the remaining tread) *and* do not meet the slid-flat criteria in Rule 82g(1) may be rematched to position the affected areas from 90° to 180° from each other (3) Flat spots that do not meet Rule 82g(1) or Rule 82g(2), no repair or replacement is needed..

- h. Damage to tires and tubes as a result of being run flat, resulting in discoloration, blistering, wrinkling, and/or casing damage being evident. To prevent run-flat damage, tires should be inflated as per Appendix B, Section B15.

### 83. Losses

Handling carriers are responsible for loss as follows:

- a. Theft of trailer, container, chassis, or bogie, or known theft of parts thereof
- b. Door or gate missing
- c. Removable side or section missing
- d. Missing tire, tube, or rim
- e. Missing assigned equipment, as outlined in Rule 71, that accompanied trailer at time of interchange
- f. Missing component parts essential for the operation of mechanical units for refrigeration or heating.

# AAR Intermodal Interchange Rules

**84. Vacant**

**85. Vacant**

**86. Vacant**

**87. Vacant**

# AAR Intermodal Interchange Rules

THIS PAGE LEFT BLANK INTENTIONALLY

# AAR Intermodal Interchange Rules

## SECTION G

### ORDINARY MAINTENANCE

#### **88. Owner Responsibility**

Refer to AAR Intermodal Interchange Rules Appendix F. for Owner's Responsibility items. Repairs, renewals, or replacement of these items shall be at the expense of the unit owner, except where directly associated with a component with Section F damage. Associated damage is damage to adjoining components occurring in the same incident.

#### **89. to 94. Vacant**

# AAR Intermodal Interchange Rules

THIS PAGE LEFT BLANK INTENTIONALLY



# AAR Intermodal Interchange Rules

## SECTION H

### REPAIRS AND BILLING

#### 95. Detailed Procedures

For more detailed procedures on repairs and billing, refer to Appendix A.

#### 96. Repairs Exceeding \$750

When the estimated cost of repairs exceeds \$750 or other amount specified by the owner, exclusive of tires, refrigeration unit, and Chassis Systematic Maintenance Inspection, repairs shall be handled under the provisions of Section L, Rule 156 or Section M, Rule 165 and Rule 166.

#### 97. Handling Line Responsibility

When a unit damaged in excess of \$750 or other amount specified by owner is returned to its owner for repairs, the carrier responsible for the damage will be responsible for those items as listed on Form J-2 or recorded image.

#### 98. Repair Cost Limit

In no case shall the cost of repairs to a unit exceed its depreciated value less salvage, except as provided in agreements between carriers and handling lines.

#### 99. Standards for Repair

When repairs are made to a unit, the regulatory standard must be maintained, and material applied must be of similar quality and type as material removed. Repairs are subject to the procedures of Appendix B. Repairs, when completed, are subject to acceptance by the unit owner. If the owner's standard(s) for the applicable repair or replacement of specific component(s) is stenciled on the unit, such standard must be followed.

#### 100. Vacant

#### 101. Repairs Requiring Authorization

Units identified with improper repair(s) by handling line should be handled as follows:

If the estimated cost of correcting improper repair(s) exceeds \$750, the cost shall be subject to acceptance by the equipment owner. Photos of improperly repaired component(s) must be furnished with authorization requests. Should it be discovered that improper repairs were performed while equipment was in possession of a handling line, the equipment owner may re-bill that handling line providing adequate support is furnished indicating that handling line's liability.

#### 102. Citations

The unit owner or lessor shall make full payment on the citation. The rail carrier in possession of the rail-controlled unit at the time of the citation may be rebilled by the unit owner or lessee.

#### 103. to 109. Vacant

# AAR Intermodal Interchange Rules

THIS PAGE LEFT BLANK INTENTIONALLY

# AAR Intermodal Interchange Rules

## SECTION I

### AUTHORITY FOR ADJUSTMENT OR TRANSFER OF INTERMODAL EQUIPMENT AND/OR INTERMODAL LADING

#### 110. Delivering Carrier Responsibility

##### a. Compliance with Loading Rules

Lading shall be properly distributed, secured, and blocked, and in compliance with Circular 43-F in the *AAR Intermodal Loading Guide for Products in Closed Trailers and Containers*, and with the *Rules Governing the Loading of Commodities on Open Top Trailers and Containers for Rail Transport (TOFC/COFC) Service* (which includes flat-bed and platform equipment).

##### b. Adjustment/Transfer of Units and Lading

Adjustment or transfer of units and/or lading shall be the responsibility of the delivering carrier as follows:

###### (1) Shifted Contents/Improper Loading

When a trailer or container is delivered by rail, street, or highway for interchange and requires adjustment of lading due to shifted contents or improper loading.

###### (2) Defective Trailer or Container

When requiring transfer or adjustment of lading due to a defective trailer or container that cannot be readily repaired.

###### (3) Defective Car/Attachment

When requiring transfer of unit due to a defective carrying car or attachment that cannot be readily repaired.

#### 111. Originating Carrier Responsibility

The following shall be the responsibility of originating carrier:

##### a. Transfer—Clearance Violation

Transfer due to clearance violation as outlined in Section A, Rule 4.

##### b. Transfer and Delivery—Overload

Transfer due to overload, if in violation of Section A, Rule 5. If a portion of the load must be transferred to another trailer or container, all costs of delivering the second trailer shall be the responsibility of originating carrier.

##### c. Damage—Overload

Damage to trailer or container due to overloading, if in violation of Section A, Rule 5.

#### 112. to 119. Vacant

# AAR Intermodal Interchange Rules

THIS PAGE LEFT BLANK INTENTIONALLY

## SECTION J

### FORMS AND REPORTS

#### 120. General Instructions

Forms and/or reports as required by these rules shall be in accord with the following provisions as to form, use, and manner of preparation. Any suitable equivalent form, report, or electronic image may be used, provided it embodies the minimum information required.

#### 121. Unit Interchange and Safety Inspection Report, Form J-1

Form J-1, equivalent, or recorded image shall be prepared by an authorized representative each time a unit is offered for interchange movement by street or highway. (See **Figure 2**.)

At locations with electronic camera technology that captures images of equipment and damage, it shall not be a requirement to provide notification of damage at time of interchange. Any invoice for damage to the equipment shall be accompanied by an electronic picture of the actual interchange of the unit showing damage with a date and time stamp.

#### 122. Unit Damage Responsibility Report, Form J-2

##### a. Preparation and Use of Form

##### (1) Damage Form and Distribution

Form J-2 (see **Figure 3**) shall be prepared by an authorized representative of the handling carrier to document damage or loss for which the handling carrier is responsible. The form shall be prepared at the place of interchange and then accompany the bill for repairs to the carrier responsible.

One copy shall be forwarded to a processor for electronic distribution and billing. One copy shall be retained by the issuing party. Copies shall be forwarded within 48 hours from the time of preparation. The processor will electronically distribute copies of Form J-2 to delivering and receiving parties.

##### (2) Recorded Image

A recorded image of the damage, taken at the time and place of interchange, may be used in lieu of a written Form J-2. This recorded image may be used to document damage or loss for which the handling carrier is responsible.

##### (3) Interchange with Unrepaired Damage Not Covered by Form

In the event a unit is offered in interchange with unrepaired damage or loss for which the delivering carrier is responsible and that is not covered by a copy of this form, the receiving carrier shall obtain from the delivering carrier a copy of Form J-2 described in Rule 122a or a recorded image of the damage.

##### (4) Time Limit for Repair

Damage covered by this report must be repaired within 60 days from date of Form J-2.

## AAR Intermodal Interchange Rules

### **(5) Associated Damage**

When performing repairs to damaged items noted on Form J-2, it is allowable to repair and bill for the associated damaged item(s) if necessary for a proper repair. Associated items must be indicated by why made code 01 on repair bill and listed in Appendix F "Complete Matrix" and in Appendix G "Association Table."

If the estimate of associated repairs exceeds \$250 or another amount specified by the responsible party, endorsement by the responsible party must be secured prior to repairs being made.

**Associated damage is damage to adjoining components occurring in the same incident.**

#### **b. Exception to Form**

After issuance, this report must not be altered and shall be binding. It is the responsibility the party taking exception to Form J-2 under provisions of Rule 122a(4), Time Limit for Repair, to provide equipment movement information to the billing party to substantiate exception.

#### **c. Provision of Rebill Authority**

When a unit is returned to its owner, the delivering carrier shall provide the owner with rebill authority within 48 hours, excluding Saturdays, Sundays, and holidays, from written or electronic notification by the owner to the delivering carrier of damages, unless in dispute. Failure to provide the owner with rebill endorsement authority, unless in dispute, shall constitute a valid acceptance by the delivering carrier of damages as specified on Form J-2 or its equivalent.

### **123. Form J-3—Authority for Transfer or Adjustment of Intermodal Equipment or Intermodal Lading**

#### **a. Preparation and Use of Form**

Form J-3 (see **Figure 5**) or electronic equivalent shall be prepared in triplicate by an authorized representative of the handling carrier when it is necessary to transfer or adjust lading in a trailer, container, or a trailer on a car, and it is the responsibility of the carrier as set forth in Section I, "Authority for Adjustment or Transfer of Intermodal Equipment and/or Intermodal Lading," of these rules.

The original form shall accompany the bill, one copy shall be forwarded to the carrier responsible, and one copy shall be retained by the handling carrier.

#### **b. Expense Responsibility**

The expense of adjustment or transfer of unit or lading shall be handled by contract.

### **124. J-4 Chassis Systematic Maintenance Inspection**

Vacant

# AAR Intermodal Interchange Rules

## 125. Authority for Counterbilling, Form J-5

### a. Purpose

Form J-5, Counterbilling Authority, shall be used for monetary adjustment between the parties concerned. (See **Figure 7**)

### b. Completion of Form

All details in Counterbilling Authority, Form J-5, must be properly filled out.

## 126. FMCSA-PI Certification, Form J-6

Form J-6 (see **Figure 8**) shall be prepared by a certified FMCSA-PI inspector as follows: the original or an electronic version thereof shall accompany the bill, one copy shall be placed on the trailer or chassis, one copy shall be forwarded to the owner within 30 days after certification, and one copy shall be for the inspector.

## 127. FMCSA-PI Certification Acknowledgment, Form J-7

a. Form J-7 (decal) (see **Figure 9**) shall be applied to the lower right front center (nose) of the trailer (curb side).

b. Form J-7 (decal) (see **Figure 9**) shall be applied on chassis on the left side main rail next to the document holder (viewable when loaded). It shall be at least 6 in. × 4½ in. in size.

The decal shall have black letters on a white background. It shall be at least 8½ in. × 8½ in. in size. Its letters shall have the following minimum dimensions:

“AAR FORM J-7”: ½ in.

“FMCSA – PI,” “MONTH, YEAR”: 1 in.

Other letters: 5/16 in.

## 128. AAR Flat File Format

The “J File” allows for the electronic exchange of damage data. Refer to Appendix D for structure and sample.

## 129. to 135. Vacant

**Figure 2 Form J-1—Unit Interchange and Safety Inspection Form**

**Form J-1**  
**UNIT INTERCHANGE AND SAFETY INSPECTION FORM**

Initial \_\_\_\_\_ Number \_\_\_\_\_  Van  Container  Chassis

Station \_\_\_\_\_ Date \_\_\_\_\_ Time \_\_\_\_\_

Delivered By \_\_\_\_\_ Received By \_\_\_\_\_

Seal No. \_\_\_\_\_ License No. \_\_\_\_\_

Origin \_\_\_\_\_ Route \_\_\_\_\_ Destination \_\_\_\_\_

MARK CLEARLY ALL DAMAGE BY INSPECTION SYMBOL "C" CUT, "B" BENT, "K" BROKEN, "M" MISSING

EXPLAIN DEFECTS:

\_\_\_\_\_  
\_\_\_\_\_  
\_\_\_\_\_  
\_\_\_\_\_  
\_\_\_\_\_

TIRE CONDITIONS: "C" CUT, "SF" SLID FLAT, "RF" RUN FLAT, "M" MISSING

ROF \_\_\_\_\_

LOF \_\_\_\_\_

RIF \_\_\_\_\_

LIF \_\_\_\_\_

ROC \_\_\_\_\_

LOC \_\_\_\_\_

RIC \_\_\_\_\_

LIC \_\_\_\_\_

ROQ \_\_\_\_\_

LOQ \_\_\_\_\_

RIQ \_\_\_\_\_

LIQ \_\_\_\_\_

RIR \_\_\_\_\_

LIR \_\_\_\_\_

ROR \_\_\_\_\_

LOR \_\_\_\_\_

INSPECTED AND EXCEPTIONS NOTED

DELIVERED BY \_\_\_\_\_ RECEIVED BY \_\_\_\_\_

INSPECTED BY \_\_\_\_\_ INSPECTED BY \_\_\_\_\_



**Figure 3 Form J-2—Intermodal Equipment Damage Form**

**INTERMODAL EQUIPMENT DAMAGE FORM J-2**

- Aluminum
- Steel
- Galvanized Steel



Equipment Initials \_\_\_\_\_ Equipment Number \_\_\_\_\_  Van  Container  Chassis

Delivered by/Responsible \_\_\_\_\_ RR. via  Street  Rail to \_\_\_\_\_ RR.

at (Station) \_\_\_\_\_ on (Date) \_\_\_\_\_  Load  Empty

Chassis: Initials/No. \_\_\_\_\_

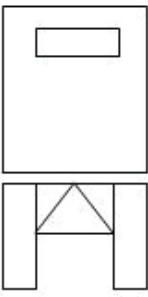
Rail Car: Initials/No. \_\_\_\_\_

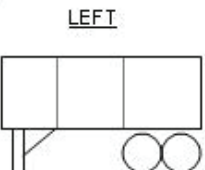
<p style="text-align: center;"><b>NOSE</b></p> <p><input type="checkbox"/> TOP NOSE RAIL <input type="checkbox"/> BENT <input type="checkbox"/> BROKEN</p> <p>QTY _____ DIMENSIONS _____</p> <p><input type="checkbox"/> NOSE PANEL(S) <input type="checkbox"/> BENT <input type="checkbox"/> CUT</p> <p>QTY _____ DIMENSIONS _____</p> <p><input type="checkbox"/> NOSE POST(S) <input type="checkbox"/> BENT <input type="checkbox"/> CUT <input type="checkbox"/> BRO.</p> <p>QUANTITY _____</p> <div style="text-align: center;">  </div> <p><input type="checkbox"/> CORNER CAPS <input type="checkbox"/> LEFT <input type="checkbox"/> RIGHT <input type="checkbox"/> BROKEN</p> <p><input type="checkbox"/> RADIUS PANEL CORNER POST <input type="checkbox"/> R- <input type="checkbox"/> BENT <input type="checkbox"/> CUT</p> <p>DIMENSIONS _____</p> <p>L- <input type="checkbox"/> BENT <input type="checkbox"/> CUT</p> <p>DIMENSIONS _____</p> <p><input type="checkbox"/> FRONTSILL <input type="checkbox"/> BENT <input type="checkbox"/> CUT <input type="checkbox"/> BRO.</p> <p>DIMENSIONS _____</p>	<p style="text-align: center;"><b>TOP</b></p> <p><input type="checkbox"/> ROOF <input type="checkbox"/> BENT</p> <p>DIMENSION _____</p> <p><input type="checkbox"/> CUT</p> <p>DIMENSION _____</p> <div style="text-align: center;">  </div> <p><input type="checkbox"/> INTERMEDIATE HEADER <input type="checkbox"/> FRONT <input type="checkbox"/> REAR <input type="checkbox"/> BENT <input type="checkbox"/> BROKEN</p> <p>FRONT DIMENSION _____</p> <p>REAR DIMENSION _____</p>	<p style="text-align: center;"><b>UNDERFRAME</b></p> <p><input type="checkbox"/> CHASSIS BOLSTER <input type="checkbox"/> FRONT <input type="checkbox"/> REAR <input type="checkbox"/> BENT <input type="checkbox"/> CUT <input type="checkbox"/> BRO</p> <p>FRONT DIMENSION _____</p> <p>REAR DIMENSION _____</p> <p><input type="checkbox"/> SLIDER RAIL <input type="checkbox"/> LS <input type="checkbox"/> RS <input type="checkbox"/> BENT <input type="checkbox"/> BRO</p> <p>LS DIMENSION _____</p> <p>RS DIMENSION _____</p> <p><input type="checkbox"/> CHASSIS CROSSMEMBER(S) <input type="checkbox"/> BENT <input type="checkbox"/> BRO</p> <p>QUANTITY _____</p> <p><input type="checkbox"/> MAIN FRAME RAIL <input type="checkbox"/> LSF <input type="checkbox"/> RSF <input type="checkbox"/> LSC <input type="checkbox"/> RSC <input type="checkbox"/> LSR <input type="checkbox"/> RSR</p> <p><input type="checkbox"/> BENT <input type="checkbox"/> CUT <input type="checkbox"/> BRO</p> <table border="1" style="width: 100%; border-collapse: collapse;"> <tr> <td style="width: 33%;">LSF DIM. _____</td> <td style="width: 33%;">LSC DIM. _____</td> <td style="width: 33%;">LSR DIM. _____</td> </tr> <tr> <td>RSF DIM. _____</td> <td>RSC DIM. _____</td> <td>RSR DIM. _____</td> </tr> </table> <p><input type="checkbox"/> CROSSMEMBER(S) <input type="checkbox"/> BENT <input type="checkbox"/> BRO</p> <p><input type="checkbox"/> LEGS <input type="checkbox"/> BAY <input type="checkbox"/> TANDEN</p> <p>QUANTITY _____</p>	LSF DIM. _____	LSC DIM. _____	LSR DIM. _____	RSF DIM. _____	RSC DIM. _____	RSR DIM. _____
LSF DIM. _____	LSC DIM. _____	LSR DIM. _____						
RSF DIM. _____	RSC DIM. _____	RSR DIM. _____						
<p style="text-align: center;"><b>SIDES</b></p> <p style="text-align: center;"><b>LEFT</b></p> <p><input type="checkbox"/> TOP SIDE RAIL <input type="checkbox"/> BENT <input type="checkbox"/> CUT <input type="checkbox"/> BRO.</p> <p>QTY _____ DIMENSIONS _____</p> <p><input type="checkbox"/> SIDE PANEL(S) <input type="checkbox"/> BENT <input type="checkbox"/> CUT</p> <p>QTY _____ DIMENSIONS _____</p> <p><input type="checkbox"/> SIDE POST(S) <input type="checkbox"/> BENT <input type="checkbox"/> CUT <input type="checkbox"/> BRO.</p> <p>QUANTITY _____</p> <p>FRONT DIMENSION _____</p> <p>REAR DIMENSION _____</p> <p><input type="checkbox"/> BOTTOM SIDE RAIL <input type="checkbox"/> BENT <input type="checkbox"/> CUT <input type="checkbox"/> BRO.</p> <p>QTY _____ DIMENSIONS _____</p> <div style="text-align: center;">  </div> <p style="text-align: center;"><b>RIGHT</b></p> <p><input type="checkbox"/> TOP SIDE RAIL <input type="checkbox"/> BENT <input type="checkbox"/> CUT <input type="checkbox"/> BRO.</p> <p>QTY _____ DIMENSIONS _____</p> <p><input type="checkbox"/> SIDE PANEL(S) <input type="checkbox"/> BENT <input type="checkbox"/> CUT</p> <p>QTY _____ DIMENSIONS _____</p> <p><input type="checkbox"/> SIDE POST(S) <input type="checkbox"/> BENT <input type="checkbox"/> CUT <input type="checkbox"/> BRO.</p> <p>QUANTITY _____</p> <p>FRONT DIMENSION _____</p> <p>REAR DIMENSION _____</p> <p><input type="checkbox"/> BOTTOM SIDE RAIL <input type="checkbox"/> BENT <input type="checkbox"/> CUT <input type="checkbox"/> BRO.</p> <p>QTY _____ DIMENSIONS _____</p>	<p style="text-align: center;"><b>REAR</b></p> <p><input type="checkbox"/> R- DOOR <input type="checkbox"/> BENT <input type="checkbox"/> BRO <input type="checkbox"/> CUT</p> <p>DIM. _____</p> <p><input type="checkbox"/> L- DOOR <input type="checkbox"/> BENT <input type="checkbox"/> BRO <input type="checkbox"/> CUT</p> <p>DIM. _____</p> <p><input type="checkbox"/> DOOR LOCKRODS <input type="checkbox"/> BENT <input type="checkbox"/> BRO <input type="checkbox"/> MSG</p> <p>L-_____, R-_____ QUANTITY _____</p> <p><input type="checkbox"/> DOOR HINGES <input type="checkbox"/> BENT <input type="checkbox"/> BRO</p> <p>L-_____, R-_____ QUANTITY _____</p> <p><input type="checkbox"/> DOOR HEADER <input type="checkbox"/> BENT</p> <p>DIMENSION _____</p> <p><input type="checkbox"/> REAR DOOR SILL <input type="checkbox"/> BENT <input type="checkbox"/> CUT <input type="checkbox"/> BRO</p> <p>DIMENSIONS _____</p> <p><input type="checkbox"/> DOOR POST <input type="checkbox"/> LR <input type="checkbox"/> RR <input type="checkbox"/> BENT <input type="checkbox"/> CUT</p> <p>L-_____, R-_____ DIMENSIONS _____</p>	<p style="text-align: center;"><b>LEGS</b></p> <p><input type="checkbox"/> LANDING LEGS <input type="checkbox"/> LSG GEAR <input type="checkbox"/> LS NON-GEAR <input type="checkbox"/> RSGEAR <input type="checkbox"/> RS NON-GEAR <input type="checkbox"/> BENT <input type="checkbox"/> BRO</p> <p>LS-_____, RS-_____ QUANTITY _____</p> <p><input type="checkbox"/> CROSSBRACE, LOWER <input type="checkbox"/> BENT <input type="checkbox"/> BRO</p> <p><input type="checkbox"/> MOUNTING BRACKET (WING PLATE) <input type="checkbox"/> LS <input type="checkbox"/> RS <input type="checkbox"/> BENT <input type="checkbox"/> BRO</p> <p><input type="checkbox"/> CRANK SHAFT <input type="checkbox"/> LS <input type="checkbox"/> RS <input type="checkbox"/> BENT <input type="checkbox"/> BRO <input type="checkbox"/> MSG</p>						
<p><input type="checkbox"/> DOT BUMPER HORIZONTAL <input type="checkbox"/> BENT <input type="checkbox"/> CUT <input type="checkbox"/> BRO <input type="checkbox"/> MSG</p> <p>DIMENSIONS _____</p>		<p><input type="checkbox"/> DOT BUMPER UPRIGHT <input type="checkbox"/> LR <input type="checkbox"/> RR <input type="checkbox"/> BENT <input type="checkbox"/> CUT <input type="checkbox"/> BRO <input type="checkbox"/> MSG</p> <p>DIMENSION _____</p>						
<p style="text-align: center;"><b>TIRES</b></p> <p style="text-align: center;">C-CUT, SF-SLID FLAT, RF-RUNFLAT, MS-MISSING</p> <p>LOF _____ LIF _____ LOR _____ LIR _____</p> <p>ROF _____ RIF _____ ROR _____ RIR _____</p> <p style="text-align: right;"><input type="checkbox"/> BIAS PLY TIRES</p> <p style="text-align: right;"><input type="checkbox"/> RADIAL TIRES</p>								

OTHER \_\_\_\_\_

Inspected by: \_\_\_\_\_

Employed by: \_\_\_\_\_

**Figure 4 Vacant**

**Figure 5 Form J-3—Authority for Transfer or Adjustment of Intermodal Equipment or Intermodal Lading**

**Form J-3**

**Intermodal Service**

No. \_\_\_\_\_

Authority for Transfer or Adjustment of Intermodal  
Equipment or Intermodal Lading

---

---

Equipment Owner  
or Initials \_\_\_\_\_ Equipment  
Number \_\_\_\_\_ Type \_\_\_\_\_

If interchanged by rail: Carrying Cars Initials \_\_\_\_\_ No. \_\_\_\_\_

Contents of Equipment \_\_\_\_\_ Name of Shipper \_\_\_\_\_

Station Loaded \_\_\_\_\_ Originating road \_\_\_\_\_

Delivered by \_\_\_\_\_ RR To \_\_\_\_\_ RR Via \_\_\_\_\_  
Rail or Street

At (Station) \_\_\_\_\_ Date \_\_\_\_\_ 20 \_\_\_\_\_

Lading in Equipment _____ (Adjusted or Transferred)	If transferred: Equipment transferred to _____ (Initials & Number)
Equipment on car _____ (Adjusted or Transferred)	If transferred: Car transferred to _____ (Initials & Number)

By \_\_\_\_\_ RR At \_\_\_\_\_ On \_\_\_\_\_ 20 \_\_\_\_\_

Account of \_\_\_\_\_

---

---

Chargeable to \_\_\_\_\_

Date Issued \_\_\_\_\_ 20 \_\_\_\_\_ Per \_\_\_\_\_

**This form must be prepared according to the procedures outlined in AAR Intermodal Interchange Rule 123**

**Figure 6 Vacant**

Figure 7 Form J-5—Counterbilling Authority

**Form J-5**

(Name of Company)

**Counterbilling Authority**

NO. \_\_\_\_\_

NO. \_\_\_\_\_

DATE: \_\_\_\_\_

(PREPRINTED ADDRESS)

DATE: \_\_\_\_\_

FILE: \_\_\_\_\_

AMOUNT: \_\_\_\_\_

THIS WILL AUTHORIZE \_\_\_\_\_

TO COUNTERBILL (*Name of Company*, Preprinted)

ISSUED TO: \_\_\_\_\_

\$ \_\_\_\_\_ DOLLARS

\_\_\_\_\_

TO ADJUST OVERCHARGE IN BILL NO. \_\_\_\_\_,  
UNDERCHARGE

ACCOUNT OF: \_\_\_\_\_

\_\_\_\_\_, ISSUED IN THE AMOUNT OF \$ \_\_\_\_\_  
(Dated)

**(State Details Here)**

\_\_\_\_\_

\_\_\_\_\_

\_\_\_\_\_

THIS AUTHORITY MUST BE  
ATTACHED TO BILL \_\_\_\_\_  
(TITLE)

**Figure 8 Form J-6—Federal Motor Carrier Safety Administration (FMCSA)  
Periodic Inspection (Sample)**

**Form J-6 (Sample)**

**Federal Motor Carrier Safety Administration (FMCSA)  
Periodic Inspection (PI)**

Trailer Initial	Trailer Number
Chassis Initial	Chassis Number
Controlling Owner	Address Where Inspections Records Are Maintained
Vehicle Identification Number (VIN)	
(Optional)	
Location Inspection Performed	

Items Checked	OK	Defect	Repaired Items
Lights			
Reflectors			
Wiring			
Brakes			
Air Lines			
Kingpin			
Tires			
Wheels and Rims			
Frame and Assembly			
Suspension			
Axles			

Tire	Pressure	Tire	Pressure	Tire	Pressure	Tire	Pressure
LOR		LOC		ROR		ROC	
LIR		LIC		RIR		RIC	
LOQ		LOF		ROQ		ROF	
LIQ		LIF		RIQ		RIF	

I certify that this unit was inspected on _____ (Month/Year) and meets requirements in accordance with 49 CFR Part 396.17.
Inspector's Name (Print)
Inspector's Signature
Name of Company Performing Repairs

**This form or similar form meeting requirements of DOT regulations must be used.**

Figure 9 Form J-7 (Sample)

*USE THIS DECAL IF FORM J-6 ACCOMPANIES VEHICLE*

FMCSA — PI

MONTH 3

YEAR 96

---

(Sample) Form J-7

*USE THIS DECAL IF FORM J-6 DOES NOT  
ACCOMPANY VEHICLE*

FMCSA — PERIODIC  
INSPECTION

CERTIFICATION

This vehicle has passed an inspection in accordance with 49 CFR Part 396 and must be reinspected during or before the same calendar month one year after the date shown below. Information on the contents of the inspection report can be obtained by contacting the Owner/Lessee.

PHONE \_\_\_\_\_

DATE OF

MO-YR — 97

---

[Stick-on Numbers]

1 2 3 4 5 6 7

8 9 10 11 12 97 98

**THIS PAGE LEFT BLANK INTENTIONALLY**



## SECTION K

### SETTLEMENT OF DISPUTES AND REVISION OF RULES

#### 136. Arbiter of Rules

The Intermodal Operations Committee of the AAR shall interpret these Rules and settle disputes thereunder. The Intermodal Operations Committee may initiate, and shall give consideration to, requests for changes to these Rules.

Disputes or questions for interpretation or arbitration arising under these rules between members to said rules may be referred to the Intermodal Operations Committee Chairman through its AAR representative in one of the following manners and formats.

#### 137. Interpretation of Rules

When formal arbitration of a dispute is not desired and the matter involves interpretation of a Rule and/or ruling on a specific case, the communication from either of the parties involved should contain all pertinent related information and, where available, copies of letters and/or unit billing repair forms associated with the particular incident.

#### 138. Formal Arbitration

##### a. Material to be Submitted

When formal arbitration of a dispute is desired, the contents of the submission to the Intermodal Operations Committee should be as follows:

##### (1) Both Parties Agree to Arbitration

Where both parties agree to arbitration, three abstracts of all pertinent information, each consisting of not more than three typewritten pages, letter size, single spaced, as follows:

1. An agreed statement of facts (signed by both parties)
2. Statement of plaintiff
3. Statement of defendant

##### (2) One Party Declines to Submit to Arbitration

Where one of the parties declines to submit to arbitration (*ex parte*), an abstract of all pertinent information consisting of not more than three typewritten pages, letter size, single spaced, shall be submitted. Where available, copies of letters and/or unit billing repair forms associated with the particular incident may accompany the abstract(s).

## AAR Intermodal Interchange Rules

### b. Procedures

The following principles should be observed in preparing cases for submission to formal arbitration, and should serve as a guide for the proper handling of other disputes:

#### (1) Roles

- (a) In the event of a dispute over responsibility for a charge that is involved in a bill, if the parties cannot reach a conclusion, the carrier against whom the bill is rendered will be the plaintiff.
- (b) In the event of dispute over a question of responsibility on a unit where a bill has not been rendered, the carrier having the unit in its possession will be the plaintiff.
- (c) In the event of a dispute in connection with a claim made for a unit damage responsibility report, the carrier instituting such claim will be the plaintiff.

#### (2) Statements

- (a) **Agreed Statement of Facts**—The plaintiff should prepare the Agreed Statement of Facts, so far as both parties are able to agree. Brief reference should also be made to the particular question upon which a decision is desired. This statement of facts, in triplicate, should be signed by both parties, one copy to be retained by the plaintiff and the original and one copy to be forwarded to the defendant.
- (b) **Plaintiff's Statement**—The defendant shall prepare in triplicate a separate statement outlining his side of the case in concise form, sign same, retain one copy, and forward the original and one copy to the defendant.
- (c) **Defendant's Statement**—The defendant shall prepare in triplicate a separate statement outlining his side of the case in concise form, sign same, and forward one copy to the plaintiff. The defendant shall forward the original statements of both parties, as well as the Agreed Statement of Facts, to the Intermodal Operations Committee AAR representative.

#### (3) Presence of Principals

Either party involved in the dispute may appear before the Intermodal Operations Committee to answer questions concerning the involved controversy and then be excused. In any dispute where a member of the Intermodal Operations Committee is a party to the dispute, the member will not be present during the discussion and decision on the matter in controversy, except to the extent permitted in this paragraph.

#### (4) Finality

The formal arbitration decisions of the Committee shall be final and binding upon the parties concerned.

### 139. Rules Revisions

The Intermodal Operations Committee shall submit, other than editorial changes, proposed rules revisions to the subscribers for comment, except those that must be promptly published due to government regulation.

### 140. to 155. Vacant

**SECTION L**

**SETTLEMENT FOR DESTROYED, BADLY DAMAGED, OR  
STOLEN UNITS—HANDLING CARRIER RESPONSIBILITY**

**156. Destroyed, Badly Damaged, or Stolen Units**

**a. Notification, Depreciated Value, and Disposition**

When the estimated cost of complete repairs to a foreign unit for which the handling company is responsible exceeds \$750 or another amount specified by the owner, exclusive of tires, the owner must be advised and requested to furnish disposition of trailer.

The owner, upon request of the handling company, shall furnish disposition at the time of notification, based on the provisions of this section.

In the absence of disposition advice within 10 working days, the handling carrier may apply Unit Damage Responsibility Report Form J-2, and forward the unit home to the owner, loaded on a freight car or on its own wheels to nearest point of interchange, advising the owner of such handling, and assuming all transportation and handling costs, except transportation over the owner's line.

Upon request, the owner shall also provide a statement showing the depreciated value of the unit.

The time limit for invoicing for destroyed or stolen units shall be no greater than 18 months from the date of last interchange.

**b. Repair Costs Over Limit**

Settlement for destroyed, badly damaged, or stolen unit shall be determined as provided in agreements between owners and handling lines.

If it is estimated by the handling carrier that the cost of complete repairs will exceed the depreciated value less salvage, the matter shall be handled as prescribed by agreements between the handling carrier and owner.

In the absence of an agreement between the owner and the handling line, the depreciated value less salvage shall be calculated using Table 1 below.

Depreciated Value = Original Purchase Price multiplied by the Factor listed below for number of months from Build Date to Loss Date. If the Original Purchase Price is not available, the last available Purchase Price should be multiplied by the Factor listed below for the number of months from Build Date to Loss Date.

## AAR Intermodal Interchange Rules

**Table 1: Depreciated Value Table (page 1 of 7)**

Asset Life (years):	20	20	15	15
Residual:	10%	5%	5%	5%
Month	Chassis	Steel Container	Aluminum Container	Trailer
1	99.625%	99.604%	99.472%	99.472%
2	99.250%	99.208%	98.944%	98.944%
3	98.875%	98.813%	98.417%	98.417%
4	98.500%	98.417%	97.889%	97.889%
5	98.125%	98.021%	97.361%	97.361%
6	97.750%	97.625%	96.833%	96.833%
7	97.375%	97.229%	96.306%	96.306%
8	97.000%	96.833%	95.778%	95.778%
9	96.625%	96.438%	95.250%	95.250%
10	96.250%	96.042%	94.722%	94.722%
11	95.875%	95.646%	94.194%	94.194%
12	95.500%	95.250%	93.667%	93.667%
13	95.125%	94.854%	93.139%	93.139%
14	94.750%	94.458%	92.611%	92.611%
15	94.375%	94.063%	92.083%	92.083%
16	94.000%	93.667%	91.556%	91.556%
17	93.625%	93.271%	91.028%	91.028%
18	93.250%	92.875%	90.500%	90.500%
19	92.875%	92.479%	89.972%	89.972%
20	92.500%	92.083%	89.444%	89.444%
21	92.125%	91.688%	88.917%	88.917%
22	91.750%	91.292%	88.389%	88.389%
23	91.375%	90.896%	87.861%	87.861%
24	91.000%	90.500%	87.333%	87.333%
25	90.625%	90.104%	86.806%	86.806%
26	90.250%	89.708%	86.278%	86.278%
27	89.875%	89.313%	85.750%	85.750%
28	89.500%	88.917%	85.222%	85.222%
29	89.125%	88.521%	84.694%	84.694%
30	88.750%	88.125%	84.167%	84.167%
31	88.375%	87.729%	83.639%	83.639%
32	88.000%	87.333%	83.111%	83.111%
33	87.625%	86.938%	82.583%	82.583%
34	87.250%	86.542%	82.056%	82.056%
35	86.875%	86.146%	81.528%	81.528%
36	86.500%	85.750%	81.000%	81.000%
37	86.125%	85.354%	80.472%	80.472%
38	85.750%	84.958%	79.944%	79.944%
39	85.375%	84.563%	79.417%	79.417%

## AAR Intermodal Interchange Rules

**Table 1: Depreciated Value Table (page 2 of 7)**

Asset Life (years):	20	20	15	15
Residual:	10%	5%	5%	5%
Month	Chassis	Steel Container	Aluminum Container	Trailer
40	85.000%	84.167%	78.889%	78.889%
41	84.625%	83.771%	78.361%	78.361%
42	84.250%	83.375%	77.833%	77.833%
43	83.875%	82.979%	77.306%	77.306%
44	83.500%	82.583%	76.778%	76.778%
45	83.125%	82.188%	76.250%	76.250%
46	82.750%	81.792%	75.722%	75.722%
47	82.375%	81.396%	75.194%	75.194%
48	82.000%	81.000%	74.667%	74.667%
49	81.625%	80.604%	74.139%	74.139%
50	81.250%	80.208%	73.611%	73.611%
51	80.875%	79.813%	73.083%	73.083%
52	80.500%	79.417%	72.556%	72.556%
53	80.125%	79.021%	72.028%	72.028%
54	79.750%	78.625%	71.500%	71.500%
55	79.375%	78.229%	70.972%	70.972%
56	79.000%	77.833%	70.444%	70.444%
57	78.625%	77.438%	69.917%	69.917%
58	78.250%	77.042%	69.389%	69.389%
59	77.875%	76.646%	68.861%	68.861%
60	77.500%	76.250%	68.333%	68.333%
61	77.125%	75.854%	67.806%	67.806%
62	76.750%	75.458%	67.278%	67.278%
63	76.375%	75.063%	66.750%	66.750%
64	76.000%	74.667%	66.222%	66.222%
65	75.625%	74.271%	65.694%	65.694%
66	75.250%	73.875%	65.167%	65.167%
67	74.875%	73.479%	64.639%	64.639%
68	74.500%	73.083%	64.111%	64.111%
69	74.125%	72.688%	63.583%	63.583%
70	73.750%	72.292%	63.056%	63.056%
71	73.375%	71.896%	62.528%	62.528%
72	73.000%	71.500%	62.000%	62.000%
73	72.625%	71.104%	61.472%	61.472%
74	72.250%	70.708%	60.944%	60.944%
75	71.875%	70.313%	60.417%	60.417%
76	71.500%	69.917%	59.889%	59.889%
77	71.125%	69.521%	59.361%	59.361%
78	70.750%	69.125%	58.833%	58.833%

## AAR Intermodal Interchange Rules

**Table 1: Depreciated Value Table (page 3 of 7)**

<b>Asset Life (years):</b>	<b>20</b>	<b>20</b>	<b>15</b>	<b>15</b>
<b>Residual:</b>	<b>10%</b>	<b>5%</b>	<b>5%</b>	<b>5%</b>
<b>Month</b>	<b>Chassis</b>	<b>Steel Container</b>	<b>Aluminum Container</b>	<b>Trailer</b>
79	70.375%	68.729%	58.306%	58.306%
80	70.000%	68.333%	57.778%	57.778%
81	69.625%	67.938%	57.250%	57.250%
82	69.250%	67.542%	56.722%	56.722%
83	68.875%	67.146%	56.194%	56.194%
84	68.500%	66.750%	55.667%	55.667%
85	68.125%	66.354%	55.139%	55.139%
86	67.750%	65.958%	54.611%	54.611%
87	67.375%	65.563%	54.083%	54.083%
88	67.000%	65.167%	53.556%	53.556%
89	66.625%	64.771%	53.028%	53.028%
90	66.250%	64.375%	52.500%	52.500%
91	65.875%	63.979%	51.972%	51.972%
92	65.500%	63.583%	51.444%	51.444%
93	65.125%	63.188%	50.917%	50.917%
94	64.750%	62.792%	50.389%	50.389%
95	64.375%	62.396%	49.861%	49.861%
96	64.000%	62.000%	49.333%	49.333%
97	63.625%	61.604%	48.806%	48.806%
98	63.250%	61.208%	48.278%	48.278%
99	62.875%	60.813%	47.750%	47.750%
100	62.500%	60.417%	47.222%	47.222%
101	62.125%	60.021%	46.694%	46.694%
102	61.750%	59.625%	46.167%	46.167%
103	61.375%	59.229%	45.639%	45.639%
104	61.000%	58.833%	45.111%	45.111%
105	60.625%	58.438%	44.583%	44.583%
106	60.250%	58.042%	44.056%	44.056%
107	59.875%	57.646%	43.528%	43.528%
108	59.500%	57.250%	43.000%	43.000%
109	59.125%	56.854%	42.472%	42.472%
110	58.750%	56.458%	41.944%	41.944%
111	58.375%	56.063%	41.417%	41.417%
112	58.000%	55.667%	40.889%	40.889%
113	57.625%	55.271%	40.361%	40.361%
114	57.250%	54.875%	39.833%	39.833%
115	56.875%	54.479%	39.306%	39.306%
116	56.500%	54.083%	38.778%	38.778%
117	56.125%	53.688%	38.250%	38.250%

## AAR Intermodal Interchange Rules

**Table 1: Depreciated Value Table (page 4 of 7)**

Asset Life (years):	20	20	15	15
Residual:	10%	5%	5%	5%
Month	Chassis	Steel Container	Aluminum Container	Trailer
118	55.750%	53.292%	37.722%	37.722%
119	55.375%	52.896%	37.194%	37.194%
120	55.000%	52.500%	36.667%	36.667%
121	54.625%	52.104%	36.139%	36.139%
122	54.250%	51.708%	35.611%	35.611%
123	53.875%	51.313%	35.083%	35.083%
124	53.500%	50.917%	34.556%	34.556%
125	53.125%	50.521%	34.028%	34.028%
126	52.750%	50.125%	33.500%	33.500%
127	52.375%	49.729%	32.972%	32.972%
128	52.000%	49.333%	32.444%	32.444%
129	51.625%	48.938%	31.917%	31.917%
130	51.250%	48.542%	31.389%	31.389%
131	50.875%	48.146%	30.861%	30.861%
132	50.500%	47.750%	30.333%	30.333%
133	50.125%	47.354%	29.806%	29.806%
134	49.750%	46.958%	29.278%	29.278%
135	49.375%	46.563%	28.750%	28.750%
136	49.000%	46.167%	28.222%	28.222%
137	48.625%	45.771%	27.694%	27.694%
138	48.250%	45.375%	27.167%	27.167%
139	47.875%	44.979%	26.639%	26.639%
140	47.500%	44.583%	26.111%	26.111%
141	47.125%	44.188%	25.583%	25.583%
142	46.750%	43.792%	25.056%	25.056%
143	46.375%	43.396%	24.528%	24.528%
144	46.000%	43.000%	24.000%	24.000%
145	45.625%	42.604%	23.472%	23.472%
146	45.250%	42.208%	22.944%	22.944%
147	44.875%	41.813%	22.417%	22.417%
148	44.500%	41.417%	21.889%	21.889%
149	44.125%	41.021%	21.361%	21.361%
150	43.750%	40.625%	20.833%	20.833%
151	43.375%	40.229%	20.306%	20.306%
152	43.000%	39.833%	19.778%	19.778%
153	42.625%	39.438%	19.250%	19.250%
154	42.250%	39.042%	18.722%	18.722%
155	41.875%	38.646%	18.194%	18.194%
156	41.500%	38.250%	17.667%	17.667%

## AAR Intermodal Interchange Rules

**Table 1: Depreciated Value Table (page 5 of 7)**

Asset Life (years):	20	20	15	15
Residual:	10%	5%	5%	5%
Month	Chassis	Steel Container	Aluminum Container	Trailer
157	41.125%	37.854%	17.139%	17.139%
158	40.750%	37.458%	16.611%	16.611%
159	40.375%	37.063%	16.083%	16.083%
160	40.000%	36.667%	15.556%	15.556%
161	39.625%	36.271%	15.028%	15.028%
162	39.250%	35.875%	14.500%	14.500%
163	38.875%	35.479%	13.972%	13.972%
164	38.500%	35.083%	13.444%	13.444%
165	38.125%	34.688%	12.917%	12.917%
166	37.750%	34.292%	12.389%	12.389%
167	37.375%	33.896%	11.861%	11.861%
168	37.000%	33.500%	11.333%	11.333%
169	36.625%	33.104%	10.806%	10.806%
170	36.250%	32.708%	10.278%	10.278%
171	35.875%	32.313%	9.750%	9.750%
172	35.500%	31.917%	9.222%	9.222%
173	35.125%	31.521%	8.694%	8.694%
174	34.750%	31.125%	8.167%	8.167%
175	34.375%	30.729%	7.639%	7.639%
176	34.000%	30.333%	7.111%	7.111%
177	33.625%	29.938%	6.583%	6.583%
178	33.250%	29.542%	6.056%	6.056%
179	32.875%	29.146%	5.528%	5.528%
180	32.500%	28.750%	5.000%	5.000%
181	32.125%	28.354%		
182	31.750%	27.958%		
183	31.375%	27.563%		
184	31.000%	27.167%		
185	30.625%	26.771%		
186	30.250%	26.375%		
187	29.875%	25.979%		
188	29.500%	25.583%		
189	29.125%	25.188%		
190	28.750%	24.792%		
191	28.375%	24.396%		
192	28.000%	24.000%		
193	27.625%	23.604%		
194	27.250%	23.208%		
195	26.875%	22.813%		



## AAR Intermodal Interchange Rules

**Table 1: Depreciated Value Table (page 6 of 7)**

Asset Life (years):	20	20	15	15
Residual:	10%	5%	5%	5%
Month	Chassis	Steel Container	Aluminum Container	Trailer
196	26.500%	22.417%		
197	26.125%	22.021%		
198	25.750%	21.625%		
199	25.375%	21.229%		
200	25.000%	20.833%		
201	24.625%	20.438%		
202	24.250%	20.042%		
203	23.875%	19.646%		
204	23.500%	19.250%		
205	23.125%	18.854%		
206	22.750%	18.458%		
207	22.375%	18.063%		
208	22.000%	17.667%		
209	21.625%	17.271%		
210	21.250%	16.875%		
211	20.875%	16.479%		
212	20.500%	16.083%		
213	20.125%	15.688%		
214	19.750%	15.292%		
215	19.375%	14.896%		
216	19.000%	14.500%		
217	18.625%	14.104%		
218	18.250%	13.708%		
219	17.875%	13.313%		
220	17.500%	12.917%		
221	17.125%	12.521%		
222	16.750%	12.125%		
223	16.375%	11.729%		
224	16.000%	11.333%		
225	15.625%	10.938%		
226	15.250%	10.542%		
227	14.875%	10.146%		
228	14.500%	9.750%		
229	14.125%	9.354%		
230	13.750%	8.958%		
231	13.375%	8.563%		
232	13.000%	8.167%		
233	12.625%	7.771%		
234	12.250%	7.375%		

# AAR Intermodal Interchange Rules

**Table 1: Depreciated Value Table (page 7 of 7)**

<b>Asset Life (years):</b>	<b>20</b>	<b>20</b>	<b>15</b>	<b>15</b>
<b>Residual:</b>	<b>10%</b>	<b>5%</b>	<b>5%</b>	<b>5%</b>
<b>Month</b>	<b>Chassis</b>	<b>Steel Container</b>	<b>Aluminum Container</b>	<b>Trailer</b>
235	11.875%	6.979%		
236	11.500%	6.583%		
237	11.125%	6.188%		
238	10.750%	5.792%		
239	10.375%	5.396%		
240	10.000%	5.000%		

**c. Salvage Value**

Salvage value shall be determined as provided in agreements between the owner and handling line. In the absence of an agreement between the owner and the handling line establishing salvage value, salvage value shall be set at zero dollars.

**157. Handling Line Repair**

If it is estimated by the handling line that damage is less than the depreciated value less salvage, it may make complete repairs of \$750 (or other amount specified by owner) or less, exclusive of tires, at its own expense, and return the unit to service.

**158. Units Requested Home for Repairs**

If the owner requests that a unit be returned home for repairs, it shall be so handled, even if the handling carrier is in a position to, and desires to, make such repairs. However, in such case, the owner shall pay all transportation costs incurred on other than the handling carrier's lines and shall assume handling costs of the damaging line, not to exceed \$200.

**159. Vacant**

**160. to 164. Vacant**

SECTION M

SETTLEMENT FOR DEFECTIVE UNITS—OWNER’S RESPONSIBILITY

**165. Notification/Authorization**

When a foreign unit has owner defects and the estimate of repairs exceeds \$750 or another amount specified by the owner (exclusive of tires and reefer/heater repairs described in Section B and Section D of these Rules), the owner must be notified and authorize repairs. Notification shall include the major defects and the estimated cost of repairs.

**166. Disposition**

The owner must furnish disposition within 10 working days of the date of notification. Authorization is assumed to be granted on the 11th day.

**a. Return Home**

If the owner elects to have the unit returned home, the owner must reimburse the handling carrier the actual cost of loading and assume the freight charges over intermediate lines.

**(1) Dispute**

If the owner elects to have the handling carrier return the unit, and upon return of the unit there is a dispute over responsibility, the handling carrier must be given an opportunity for a joint inspection.

**b. Disposal**

If the owner elects to have the handling carrier dispose of the unit, the handling carrier shall scrap the unit and provide proof that the unit was scrapped.

**167. to 170. Vacant**

# AAR Intermodal Interchange Rules

THIS PAGE LEFT BLANK INTENTIONALLY

## SECTION N

### LOCATIONS AND STENCILING

#### 171. Location Designations

For uniformity in reporting location of unit parts in connection with inspection or repairs, the following will govern. Such location designations shall be shown on all repair bills, forms, or reports submitted where location information is involved.

##### a. Front/Rear

The end of the unit to which the tractor power unit is attached shall be known as the front end, and the opposite end shall be known as the rear end.

##### b. Sides and Top

Sides and top of units are designated as front, center, and rear depending on the type of equipment. For a van or chassis, the dolly legs forward is the front (LSF, RSF, TF), the dolly legs to the tires is the center (LSC, RSC, TC), and the tires to the back is the rear (LSR, RSR, TR). For a container with stacking posts, the front stacking post forward is the front (LSF, RSF, TF), between the stacking posts is the center (LSC, RSC, TC), and the rear stacking post to the back is the rear (LSR, RSR, TR). For 20 ft and 40 ft containers, the sides and top are designated as center (LSC, RSC, TC).

##### c. Tires and Axles

Facing the rear end of the unit, the side to the right shall be known as the right side, and wheels, tires, rims, etc., shall be known as right outside rear (ROR), right inside rear (RIR), right outside quad (ROQ), right inside quad (RIQ), right outside center (ROC), right inside center (RIC), right outside front (ROF), and right inside front (RIF).

Similarly, the side to the left shall be known as the left side, and locations shall be known as left outside rear (LOR), left inside rear (LIR), left outside quad (LOQ), left inside quad (LIQ), left outside center (LOC), left inside center (LIC), left outside front (LOF), and left inside front (LIF).

If only a single axle assembly is involved, it shall be considered as "rear," and if a triple axle assembly is involved, the designations shall be "front," "center," and "rear." If a quad axle assembly is involved, the designations shall be "front," "center," "quad," and "rear." If single wheels are involved instead of dual wheels, single wheels shall be designated as "outside."

## AAR Intermodal Interchange Rules

### 172. Stenciling—Weight, Height, Capacity

All trailer, container, and chassis equipment used in interchange service must carry stenciling, preferably on the lower portion of the left side, near the front end of the unit, showing the empty weight and height of the unit, using not less than 2 in. letters and figures. In addition to the empty weight, trailers and containers handling bulk liquid commodities must carry stenciling to indicate capacity in U.S. gallons.

#### a. Alteration of Stencils

The empty weight of the trailer or container or its capacity in U.S. gallons may not be altered or applied to the trailer or container except by the owner or lessee of the trailer or container.

#### b. Included in Empty Weight

Only such removable items that are a permanent part of the trailer, including the full complement of items stenciled on the nose of the trailer in accordance with Section E, Accessories and Special Equipment, and that accompany the trailer at all times shall be included in stenciled empty weight.

# AAR Intermodal Interchange Rules

### Figure 10 Quad Axle Diagram

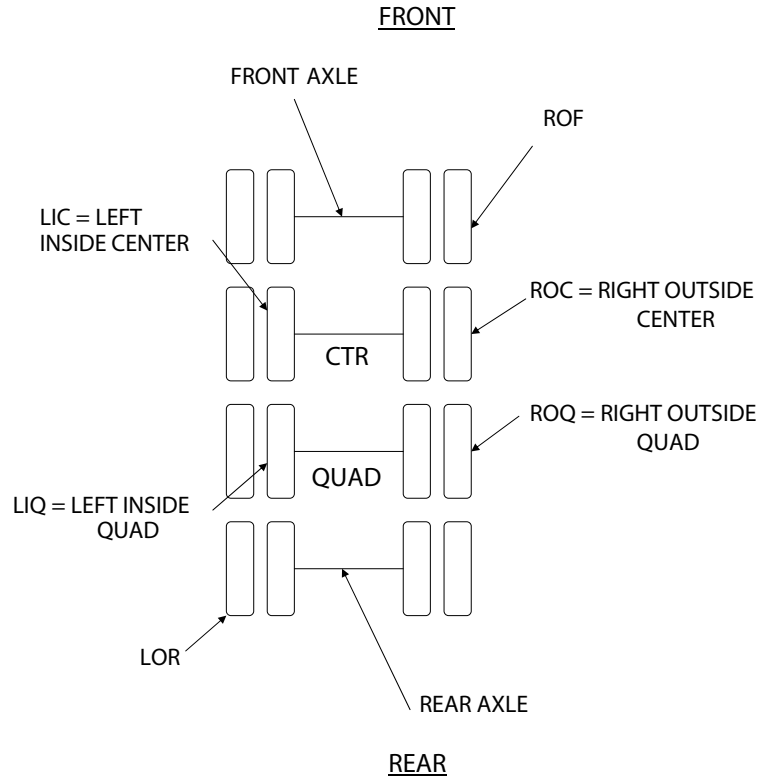

### Figure 11 Tri- and Double-Axle Diagram

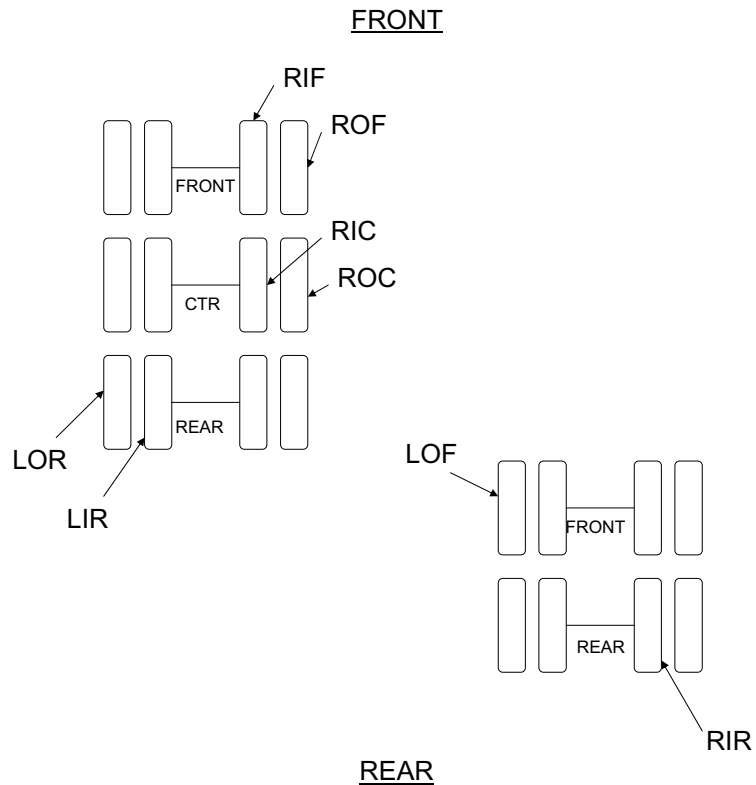

# AAR Intermodal Interchange Rules

**Figure 12 Axle Diagram (Side)**

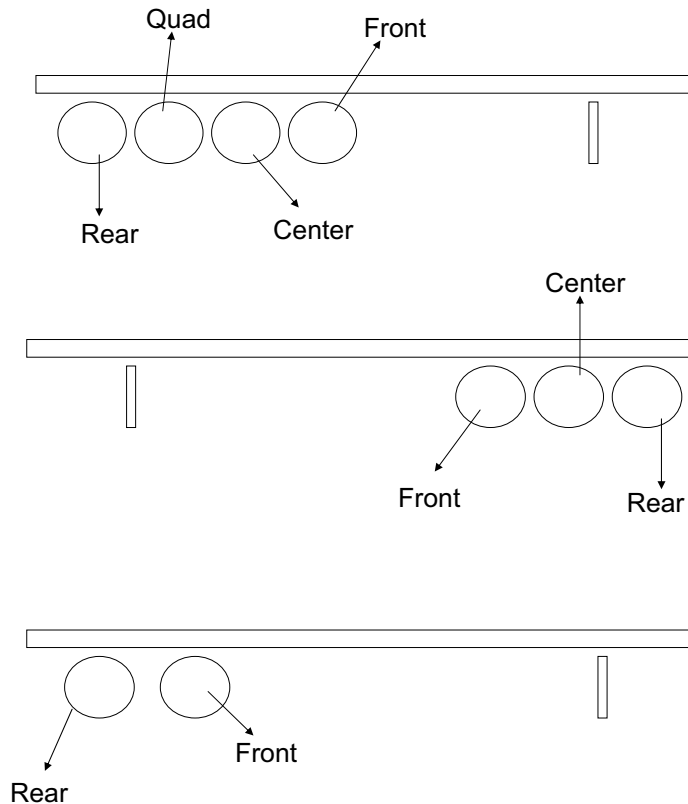

## 173. Reporting Marks and Numbers

To ensure readability of lettering or marking of units, the following shall govern:

### a. Trailers or Containers

Reporting marks and numbers shall be not less than 6 in. in height on each side of the trailer or container, and not less than 6 in. in height on the front and rear of the trailer or container.

### b. Chassis

Chassis not attached to a container shall have the name or initials of the owner or lessee and the number of the unit applied at one or more locations on the unit, using not less than 3 in. letters and figures on the front and rear, and not less than 6 in. in height on each side. A metal ownership plate showing this information, securely attached to the frame of the unit, is acceptable.

### c. Non-Satisfactory Markings

Except as provided in paragraph e. of this rule, paper, cardboard, or similar material that is pasted, glued, or taped to the exterior of the unit or to sign boards attached to the unit to indicate identification markings for reporting purposes, is not proper or satisfactory marking under this rule.



# AAR Intermodal Interchange Rules

## d. Short Term Leasing

In the event a unit is operated under a short term leasing arrangement, such as one called “one trip leasing,” or any other leasing arrangement not exceeding 10 days duration, and the lessee desires that the unit carry the lessee’s identification markings for reporting purposes, such markings need not comply with provisions of paragraph c. of this rule.

## e. Change in Status

When a change occurs in either ownership or lessee status and it is desired or becomes necessary to change identification markings used for reporting purposes, previous identification markings and placards and/or stencil markings used for reporting purposes must be removed or obliterated.

## 174. Hazardous Placards

Hazardous material placards must be positioned to be visible on the left and right sides and front and rear ends of containers when loaded on railcars.

- a. For the left and right sides of containers, the bottom of the placards must be positioned 5 ft above the bottom rail or 5 ft above the bottom support structure of a portable tank, and the side of the placards must be positioned 5 ft from the corner post or end support structure of a portable tank
- b. For the front and rear ends of containers, the bottom of the placards must be positioned 5 ft feet above the bottom rail or 5 ft above the bottom support structure of a portable tank.

**Figure 13 Placement of hazardous placards**

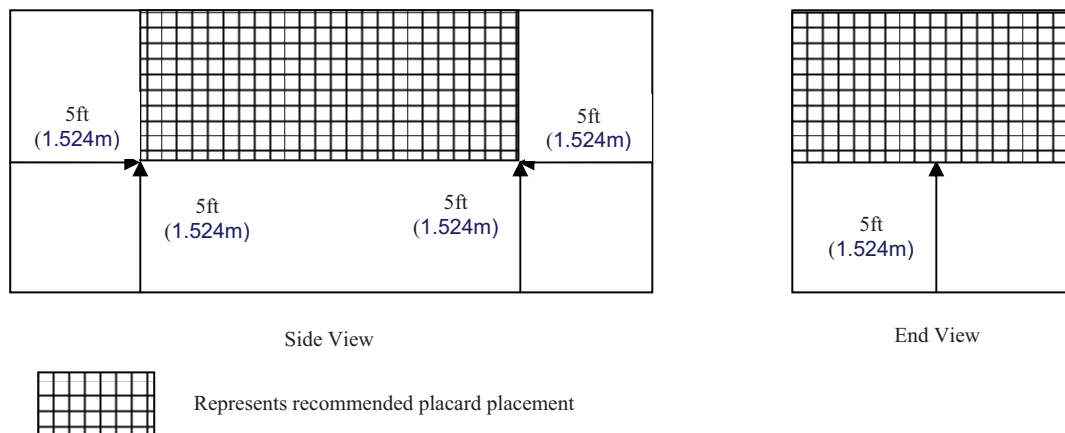

## 175. Vacant

## 176. to 179. Vacant

# AAR Intermodal Interchange Rules

SECTION N

LOCATIONS, MARKINGS, AND AEI

---

THIS PAGE LEFT BLANK INTENTIONALLY

# AAR Intermodal Interchange Rules

## SECTION O

### CONDITIONS OF ACCEPTANCE

#### **180. Vacant**

#### **181. Acceptance of Rules**

Acceptance or rejection of the AAR Intermodal Interchange Rules by AAR member railroads must be as a whole. However, AAR member railroads may, by mutual agreement, waive or alter any of these rules as between themselves.

# AAR Intermodal Interchange Rules

THIS PAGE LEFT BLANK INTENTIONALLY

# AAR Intermodal Interchange Rules

## SECTION P

### SUBSCRIPTION TO THE *INTERMODAL INTERCHANGE RULES*

#### **182. Notification**

A subscriber to the *Intermodal Interchange Rules*, by registering, will receive notification of updates to the Intermodal Interchange Rules.

#### **183. Subscription**

Any corporation, partnership, individual, railroad, railroad subsidiary motor carrier, leasing company, forwarding company, shipper, shipper association, motor common carrier, or water carrier engaged in intermodal service may subscribe to the *Intermodal Interchange Rules* by registering as an “AAR Intermodal Interchange Rules Subscriber” on the AAR Web site <http://www.aar.com/standards/IntermodalOperations-interchange-rules.html>.

#### **184. Availability**

The *Intermodal Interchange Rules* are available for viewing or printing at no cost on the AAR Web site <http://www.aar.com/standards/IntermodalOperations-interchange-rules.html>. A printed copy can be purchased through the AAR.

# AAR Intermodal Interchange Rules

THIS PAGE LEFT BLANK INTENTIONALLY

## SECTION Q

### PROPOSED CHANGES TO AAR *INTERMODAL INTERCHANGE RULES*

#### 185. Procedure for Proposing Changes

- a. Proposed changes are made to the AAR through their Web site  
<http://www.aar.com/standards/IntermodalOperations-interchange-rules.html>.
- b. All proposed changes are brought before the AAR Intermodal Operations Committee (IOC) for review, discussion, and voting for inclusion or non-inclusion in the AAR *Intermodal Interchange Rules*.
- c. In the event that the IOC determines that it is necessary to distribute a proposed rule change to subscribers for comment, the IOC will review any comments received and make a final vote for inclusion or non-inclusion in the AAR *Intermodal Interchange Rules*.
- d. All changes that receive a final vote for inclusion in the AAR *Intermodal Interchange Rules* will be provided to the AAR Director—Business Services. AAR will be responsible for publication of a complete document with an updated effective date made available in electronic format on the AAR Web site  
<http://www.aar.com/standards/IntermodalOperations-interchange-rules.html>.
- e. Upon update of the AAR *Intermodal Interchange Rules*, all subscribers will be notified via email that the new version is available in electronic format on the AAR Web site  
<http://www.aar.com/standards/IntermodalOperations-interchange-rules.html>.

# AAR Intermodal Interchange Rules

THIS PAGE LEFT BLANK INTENTIONALLY



## APPENDIX A

### BILLING PROCEDURES

#### A1. Required Documents

##### a. Form J-2

When repairs are covered by a Unit Damage Responsibility Report (Form J-2 or recorded image), an original, copy, or electronic image of such report must accompany the Unit Billing Repair Form.

##### b. FMCSA Inspections

When billing for FMCSA periodic inspections, the bill for associated repairs, if any, must be included with the original, copy, or electronic version of Form J-6.

#### A2. Repair Records

A repair record must be prepared when repairs of any kind are made.

##### a. Generation and Retention

When repairs are made to a foreign unit, an original record of repair must be made in detail at the unit.

##### b. Required Information

The following basic information is common to both the original record of repairs and the Unit Billing Repair Form and must be shown at all times:

- (1) Reporting marks (unit initials)
- (2) Unit number
- (3) Date repairs completed (Mo-Day-Year)
- (4) Repair point locations (Standard Point Location Code, SPLC)

#### A3. Billing Categories

Separate bills must be prepared for the following:

- a. Settlement for units destroyed or stolen
- b. Settlement for units requiring repair. If a repair invoice is for the same party, one bill should be issued to cover damages billed per J2, repair absorbed as handling line, and billing (charges/no bill) to owner.
- c. Transfer or adjustment of loads
- d. Tolls and citations

# AAR Intermodal Interchange Rules

## A4. Billing Formats

Unit repair billing must be submitted in mechanized billing per Rule A5

## A5. Mechanized Billing

Mechanized billing must:

- a. Itemize all repairs
- b. Include all repairs billed
- c. When produced, be printed on standard letter size (8½ in. × 11 in.) stock, with only one unit bill per sheet. Alternatively, as provided by agreement between the billing and responsible parties, billing may be performed through any means agreed upon.

### d. Required Information:

- (1) Name of billing company
- (2) Name of company performing repairs, if other than billing company
- (3) Unit initial and number
  - (a) If container and chassis are mated, initial and number of mate must be shown. If repairs are performed on both units of a mated container and chassis, a separate billing sheet must be prepared for each unit.
- (4) Geographic location (SPLC) of repair
- (5) Date of repair
- (6) If applicable, a reference number corresponding to the Form J-2 supporting generation of the bill under Rule 122
- (7) The Location Code corresponding to the location of the defect on the unit as per Rule A10
- (8) The Job Code applicable to the component to be repaired or replaced as a result of the defect reported. If Job Codes other than those listed in Appendix F are used, a description of the component to which the Job Code is applicable must be furnished to the party receiving the bill.
- (9) The Why Made Code applicable to the defect, as listed in Rule A10. If Why Made Codes other than those listed in Rule A10 are used, a description of the defect must be provided to the party receiving the bill.
- (10) The Condition Code applicable to the repair performed to correct the defect, as per Rule A10
- (11) If the repair does not replace the component affected by the defect, the size of the defect addressed by the repair, measured in linear inches or square inches as appropriate for the repair being performed (for Condition Codes indicating that a patch, section, overlay, insert, or weld was applied to make the repair).

## AAR Intermodal Interchange Rules

- (12) When repairs utilize a combination of Location Codes, Job Codes, Why Made Codes, and Condition Codes not contained in Appendix F, a description of repairs made, with all such descriptions limited to no more than 255 characters
  - (13) The quantity of components matching the Location Code, Job Code, Why Made Code, and Size used to describe the repair
  - (14) Labor and material charges, shown separately
  - (15) Column totals for labor and material
  - (16) Total charges billed
  - (17) When the total amount billed, excluding tires, exceeds \$1,000 (or other amount specified by owner), unit built date must be included
  - (18) Labor shall be shown to the nearest 1/20th hour
  - (19) Taxes, where applicable, shown separately
- e. Vacant
- f. Have the support data used to generate mechanized bill retained and made available for inspection and/or audit no less than 365 days from the date of billing, unless otherwise provided in separate agreements.

### A6. Vacant

### A7. Exceptions

When exceptions are taken to a Unit Billing Repair Form, the entire form will be rejected.

### A8. No Bills

A record of all repairs performed and not billed to the owner must be included in the monthly billing.

- a. Submit the original bill or workorder, or a copy of the original bill or workorder.
- b. Submit electronically.
- c. Documentation shall be included with monthly statement or as a separate attachment, but clearly grouped as "No Bills."
- d. Every "No Bill" repair should be forwarded to the owner, unless covered by private contract.

# AAR Intermodal Interchange Rules

## A9. Handling of Bills

Bills for repairs to equipment covered by these Rules shall be handled as follows:

### a. Calculation Date of Charges

Charges must be calculated as of the date of repairs.

### b. Owner Responsibility

Charges for all repairs for which the owner is responsible shall be billed against the owner.

### c. J-2 Repairs

Charges for repairs authorized by the Unit Damage Responsibility Report, Form J-2 or recorded image, shall be billed against the company shown thereon. The original Form J-2/recorded image or a copy thereof shall accompany the billing.

### d. Consolidation of Charges

A separate Unit Billing Repair Form and bill shall be submitted for repairs to individual units of equipment, and all charges for repairs shall be consolidated against any one company into one separate statement, listing supporting invoices by unit number and amount. An index of billing forms with unit numbers and amounts billed each unit shall be located directly behind the cover sheet of the bill.

### e. Time Limits

All bills should be rendered promptly. Bills rendered after 75 days from the date of repairs may be declined. Parties waive all rights to dispute invoices issued in accordance with these rules and not disputed within 30 days from the date the bill was issued.

### f. Corrections

- (1) When a repair bill is rejected due to incorrect information, the invoicing party will have 30 days after notification to correct the repair bill and resubmit.

### g. Units Retired vs. Repaired

Where a unit reaches home with a Unit Damage Responsibility Report, Form J-2, attached under provisions of Section L, or with other unfair usage damage covered by a Unit Damage Responsibility Report, and the owner elects to retire instead of repair the unit, a charge may be made for material and labor, as would have been required for repairing or renewing items actually listed on the Damage Responsibility Report. Excluding labor and material for undamaged associated parts, such bill should be rendered within 90 days of the first receipt of the unit home, whether or not the unit has been actually disposed of or dismantled. In no case, however, shall the total bill exceed the depreciated value less salvage, except as provided in agreements between owners and handling lines.

## AAR Intermodal Interchange Rules

### A10. Condition, Why Made, Responsibility, and Location Codes

Condition Codes		Responsibility Codes	
Temporary Repair	0	Owner	01
Replace w/New	1	Handling Line	02
Replace w/Used	2	Form J-2	03
Replace w/Remfg/Recap	3	Form J-3	04
RR&R	4	Form J-4	05
R&R	5	Form J-5	06
Material Only	6	Other	07
Labor Only	7	Form J-1	08
Straighten	8		
Seal	9		
Secure	A		
Patch	B		
Section	C		
Weld	D		
Patch, Buck Rivets	E		
Patch, SS Pop Rivets	F		
Section, Buck Rivets	G		
Overlay	H		
Insert	I		
Inspection,NoRepairRequired	J		
Inspection,RepairRequired	K		

## AAR Intermodal Interchange Rules

### Why Made Codes

Associated With Repairs	01	Correct Improper Repair	20
Bent	02	Corrosion	21
Broken	03	Rotted	22
Defective	04	Flex Cracks	23
Inoperative	05	Burned Out	24
Leaking	06	State/Federal/Insp.	25
Loose	07	Vandalism	26
Missing	08	Dirty, Nails, Dunnage	27
Slick Tread	09	Warranty	28
Separated Cap	10	Retire/Destroyed	29
Blister	11	Terminated	30
Run Flat	13	Lost/Stolen	31
Cut, Torn	14	Per Contract	32
Worn Out	15	Railroad Damage	33
Flat Tire	16	Slid Flat	34
Channel Crack or Weather Check	17	Close and Secure Door	35
Weld Broken	18	Contaminated	36
Internal Failure	19	Driver Vehicle Inspection Report	37

### Location Codes

LIC	left inside center	RIC	right inside center
LIF	left inside front	RIF	right inside front
LIQ	left inside quad	RIQ	right inside quad
LIR	left inside rear	RIR	right inside rear
LOC	left outside center	ROC	right outside center
LOF	left outside front	ROF	right outside front
LOQ	left outside quad	ROQ	right outside quad
LOR	left outside rear	ROR	right outside rear
LS	left side	RS	right side
LSC	left side center	RSC	right side center
LSF	left side front	RSF	right side front
LSR	left side rear	RSR	right side rear
LF	left front	RF	right front
LR	left rear	RR	right rear
F	front	T	top
R	rear	TC	top center
I	interior	TF	top front
U	under	TR	top rear
C	complete		

# AAR Intermodal Interchange Rules

## A11. Organization of Job Codes

- a. 1000–1999—Tires/Rims
- b. 2000–2799—Suspension and Tandems
- c. 2800–2999—Air Ride
- d. 3000–3999—Unders Construction—Below Floor, Except Tandem
- e. 4000–4999—Body Construction
- f. 5000–5099—Chassis Frame
- g. 5100–5299—Chassis Rack
- h. 5300–5399—Containers
- i. 5400–5899—Miscellaneous
  - (1) 5400 - 5700 Misc.
  - (2) 5701 - 5709 DVIR Inspections
  - (3) 5710 - 5899 Misc.
- j. 5900–5999—Vacant
- k. 6000–6299—Mechanical Refrigeration/Heater Units
- l. 6300–6499—Vacant
- m. 6500–6799—Tank Containers
- n. 6800–6990—Vacant
- o. 6991–6999—Taxes
- p. 7000–7999—Reserved for Expansion
- q. 8000–9999—Reserved for Individual Railroads

**Figure 14 Association of American Railroads Unit Repair Billing Form**

## ASSOCIATION OF AMERICAN RAILROADS UNIT REPAIR BILLING FORM

SPLC	R E M I T  T O		TRAILER/CONT INITIALS/NUMBER	REPAIR KIND  [O] THER		
PAYEE / SHOP ID		MANUFACTURER				
J-2 RESPONSIBILITY		DATE BUILT MO/YR				
J-2 DATE:		INVOICE NUMBER:                      DATE:		CHASSIS INITIALS/NUMBER		
			REPAIR AUTH DATE	REPAIR COMPLETION DATE		
			REPAIRED AT	RAMP	SHOP	DELAY DAYS

JOB CODE	DEBIT CREDIT	R	R	C	WHY MADE	RR MAT	LOCATION	LABOR HOURS	QTY	NEW PART NUMBER	REPAIR DESCRIPTION	MAT'L/LABOR AMOUNT

LOADED/EMPTY: \_\_\_\_\_ AUTHORIZED: \_\_\_\_\_ AUTH NUMBER: \_\_\_\_\_ INVOICE TOTAL:

- |   |  |   |
|---|--|---|
| <p><b>R.C.—REPAIR CONDITION</b></p> <ul style="list-style-type: none"> <li>0 Temporary Repair</li> <li>1 Replace w/ New</li> <li>2 Replace w/ Used</li> <li>4 RR &amp; R</li> <li>5 R &amp; R</li> <li>6 Material Only</li> <li>7 Labor Only</li> <li>8 Straighten</li> <li>9 Seal</li> <li>A Secure</li> <li>B Patch</li> <li>C Section</li> <li>D Weld</li> <li>E Patch, Buck Rivets</li> <li>F Patch, SS Pop Rivets</li> <li>G Section, Buck Rivets</li> <li>H Overlay</li> <li>I Insert</li> <li>J Inspection, No Repair Required</li> <li>K Inspection, Repair Required</li> </ul> | <p><b>WHY MADE CODES</b></p> <ul style="list-style-type: none"> <li>02 Bent</li> <li>03 Broken</li> <li>04 Defective</li> <li>05 Inoperative</li> <li>06 Leaking</li> <li>07 Loose</li> <li>08 Missing</li> <li>14 Cut, Torn</li> <li>15 Worn Out, Det.</li> <li>18 Weld Broken</li> <li>19 Internal Failure</li> <li>20 Correct Improper Repair</li> <li>21 Corrosion</li> <li>22 Rotted</li> <li>23 Flex Cracks</li> <li>24 Burned Out</li> <li>25 State/Federal/Insp.</li> <li>26 Vandalism</li> <li>27 Dirty, Nails, Dunnage</li> <li>28 Warranty</li> <li>29 Retire/Destroyed</li> <li>30 Terminated</li> <li>31 Lost/Stolen</li> <li>32 Per Contract</li> <li>33 Railroad Damage</li> <li>35 Close and Secure Door</li> <li>36 Contaminated</li> <li>37 Driver Vehicle Inspection Report (DVIR)</li> </ul> | <p><b>LOCATION CODES</b></p> <ul style="list-style-type: none"> <li>C Complete Unit R &amp; L</li> <li>F Front</li> <li>R Rear</li> <li>I Interior</li> <li>LF Left Front</li> <li>RF Right Front</li> <li>LR Left Rear</li> <li>RR Right Rear</li> <li>LS Left Side</li> <li>RS Right Side</li> <li>LSC Left Side Center</li> <li>LSF Left Side Front</li> <li>LSR Left Side Rear</li> <li>RSC Right Side Center</li> <li>RSF Right Side Front</li> <li>RSR Right Side Rear</li> <li>T Top</li> <li>TC Top Center</li> <li>TF Top Front</li> <li>TR Top Rear</li> <li>U Under</li> </ul> |
|---|--|---|



**Figure 15 Association of American Railroads Tire Repair Billing Form**

**ASSOCIATION OF AMERICAN RAILROADS  
TIRE REPAIR BILLING FORM**

SPLC	REMIT TO	TRAILER/CONTAINER INITIALS/NUMBER		REPAIR KIND
PAYEE/SHOP ID		MANUFACTURER/		
J2 RESPONSIBILITY		INVOICE NUMBER:	DATE BUILT MO/YR	
J2 DATE		DATE:	CHASSIS INITIALS/NUMBER	
		REPAIR DATE		

JOB CODE	DEBIT CREDIT	R R	R C	WHY MADE	RR MAT	LOCATION	LABOR HOURS	QTY	TIRE SIZE	REPAIR DESCRIPTION	MATERIAL/LABOR AMOUNT
Invoice Total:											

Loaded/Empty \_\_\_\_\_ Authorized: \_\_\_\_\_ Authority Number: \_\_\_\_\_

Tires	Loc	Brand	Serial No.	Cappers Code	Tires	Loc	Brand	Serial No.	Cappers Code	Tires	Loc	Brand	Serial No.	Cappers Code
Applied														
Removed														

- |   |  |  |  |
|---|--|--|--|
| <p><b><u>R.R.-REPAIR RESPONSIBILITY</u></b></p> <p>01 Owner<br/>03 J-2<br/>07 Other<br/>08 Form J-1<br/>09 Damage</p> | <p><b><u>R.C. - REPAIR CONDITION</u></b></p> <p>1 Replace W New<br/>3 Replace W Refmg Recap<br/>7 Labor Only<br/>B Patch</p> | <p><b><u>Why Made</u></b></p> <p>01 Assoc. w/Repairs<br/>08 Missing<br/>09 Slick Tread<br/>10 Separated Cap<br/>11 Blister, Knots<br/>13 Run Flat<br/>14 Cut, Torn<br/>16 Flat Tire<br/>17 Weather Chk/Chan. Crack<br/>20 Correct Improper Repair<br/>34 Slid Flat</p> | <p><b><u>Location Codes</u></b></p> <p>ROR Right Outside Rear<br/>RIR Right Inside Rear<br/>ROF Right Outside Front<br/>RIF Right Inside Front<br/>ROQ Right Outside Quad<br/>RIQ Right Inside Quad<br/>ROC Right Outside Center<br/>RIC Right Inside Center<br/>LOR Left Outside Rear<br/>LIR Left Inside Rear<br/>LOF Left Outside Front<br/>LIF Left Inside Front<br/>LOQ Left Outside Quad<br/>LIQ Left Inside Quad<br/>LOC Left Outside Center<br/>LIC Left Inside Center</p> |
|---|--|--|--|

# AAR Intermodal Interchange Rules

## APPENDIX B

### CORRECT UNIT REPAIR PROCEDURES

#### B1. Introduction

##### a. Preface

This Appendix details procedures and methods for the repair of trailer, container, and chassis equipment to permit its safe return to service. The purpose of any repair is to restore the equipment to its original structural integrity. The OEM repair manual should be consulted first. If an OEM repair standard is not available, this Appendix describes the materials and method required by the AAR *Intermodal Interchange Rules*. All repairs and replacements are subject to the applicable provisions of this Code of Rules and all regulatory specifications.

This Appendix is divided into sections detailing repairs by component groups.

##### b. Proper Repairs

It is important that each area of defect on a unit be carefully evaluated and proper repairs and/or replacements be made. The types of unit defects discussed in this repair manual are not intended to indicate that they are the only types of structural defects that should be repaired. Each unit or area of defects should be reviewed individually and a repair decision made based on that review.

##### c. Equipment Component Compatibility

Original equipment components as manufactured, approved, and recommended by the builder of the unit are selected for their compatibility with each of the other elements of the unit; therefore, only original replacement parts or compatible materials should be used for recommended repairs.

##### d. Owner's Requirements

If the owner's standard(s) for applicable repair or replacement of specific component(s) are stenciled on the unit, such repair or replacement must be followed as prescribed in Rule 99.

##### e. Tamper Evidence Requirement

All repairs must be completed in a manner that makes it impossible to add or remove lading without visible traces of repair tampering.

# AAR Intermodal Interchange Rules

## B2. General Trailer/Container Repairs

### a. Post and Panel Damage

Generally, post and/or panel damage can be repaired by splices and/or patches (refer to Body Repairs, following). If the extent of the damage is such that an effective structural repair by reinforcing the damaged area is questionable, replacement of parts is recommended rather than splicing and/or patching. All post and panel damage to be repaired should be evaluated on an individual basis and repairs made based on that review. In all cases, the original trailer or container manufacturer should be consulted for repair recommendations.

### b. Joining Dissimilar Materials

Joining of dissimilar metals and other materials involves procedures that will, if done properly, prevent or control corrosion that may occur in certain atmospheric or moisture conditions. Improper application of protective coatings between surfaces of dissimilar metals can leave the materials open to severe galvanic actions. (In refrigerated trailers or containers, for example, when the space between two different metals is filled by a fluid that can conduct electricity, one of the metals will gradually decompose.) Corrosion also occurs when wood parts are not protected adequately prior to their assembly to metal surfaces.

The procedures listed below will, within practical limits, prevent such corrosion.

#### (1) Joining Aluminum to Unfinished Steel or Stainless Steel

- (a) Before assembling aluminum to steel, including crossmembers to bottom rail, the surface of the steel must be cleaned of all rust, scale, weld flux, metal particles, and other foreign material.
- (b) Immediately after cleaning:
  - 1) Apply a primer to the steel surface to prevent galvanic action.
  - 2) Apply a protective coating to the steel area.
  - 3) Apply insulating tape.
- (c) Exterior steel number and logo placards and similar exposed steel items shall be protected with insulating tape prior to assembly to an aluminum surface.
- (d) Replacement fasteners must be of similar metals; screws, bolts, nuts, and nails; and protective coatings must be used.

#### (2) Joining Aluminum and Wood Components

- (a) Apply a protective coating to wood surfaces.
- (b) Sealers that are flexible and non-shrinking shall be used in highly corrosive areas to prevent deterioration of the wood, including trailer or container doors and door frame areas.

# AAR Intermodal Interchange Rules

## B3. Body Repairs (Side Panels)

### a. Mating of Panels

Material selected for replacing side wall panels shall comply with the manufacturer's recommendation, with corrugated or smooth panel construction mated under all circumstances, including patches. Prepainted panels must likewise be mated.

### b. Repairing Body Panels of Sheet and Post Trailers and Containers

- (1) A patch panel of like material shall be made to overlap the existing panel break of not less than 1 in. on all sides for small repairs. On larger breaks, the damaged portion must be trimmed to produce a round or oblong opening. No patch shall be less than 4 in. on any one side (see **Figure B-1**).

**Figure B-1 Patching Panels**

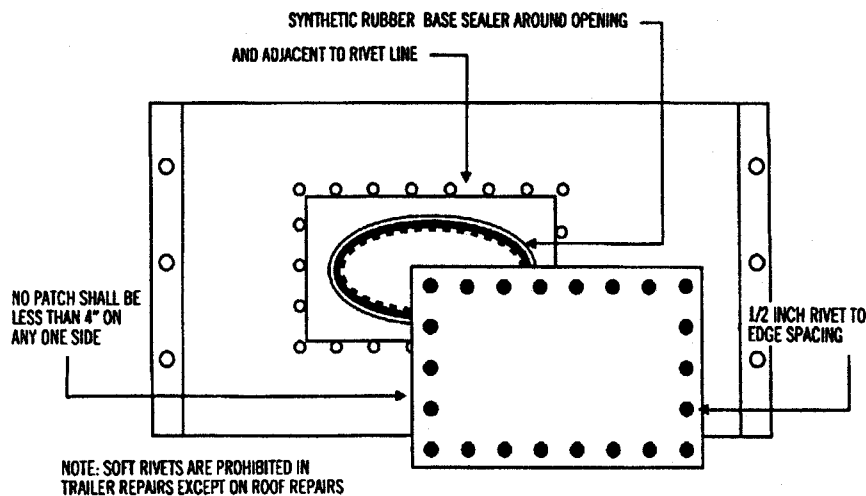

- (2) Aluminum panel patches shall be the same thickness as the original.
- (3) Clean and deburr both panel and patch. Smooth any dented or creased area around the damaged area.
- (4) Place the panel patch over the break to include any badly dented or creased areas; drill holes for rivet securement around the patch perimeter, spaced on 1½ in. centers. Rivet holes shall be located not less than ½ in. from the edges of the patch.
- (5) Apply a non-shrinking sealer between the patch and trailer body.

One bead must be applied around the perimeter of the damaged area. The other bead must be adjacent to the rivet line, and applied in a manner that does not allow an excessive amount of sealant to seep to the outside perimeter of the patch.

- (6) A self-sealing pop rivet is the correct hardware to use on side panel repairs (excludes drive rivets and screws).

## AAR Intermodal Interchange Rules

- (7) For securement of panels to posts to the trailer or container structure, buck rivets and/or structural mono bolts must be used. Self-sealing pop rivets may be used only at the rail area where there is no rear access due to the trailer's or container's structural configuration.
- (8) A patch cannot extend from one panel to another (**Figure B-1a**).

**Figure B-1a Patching Panels**

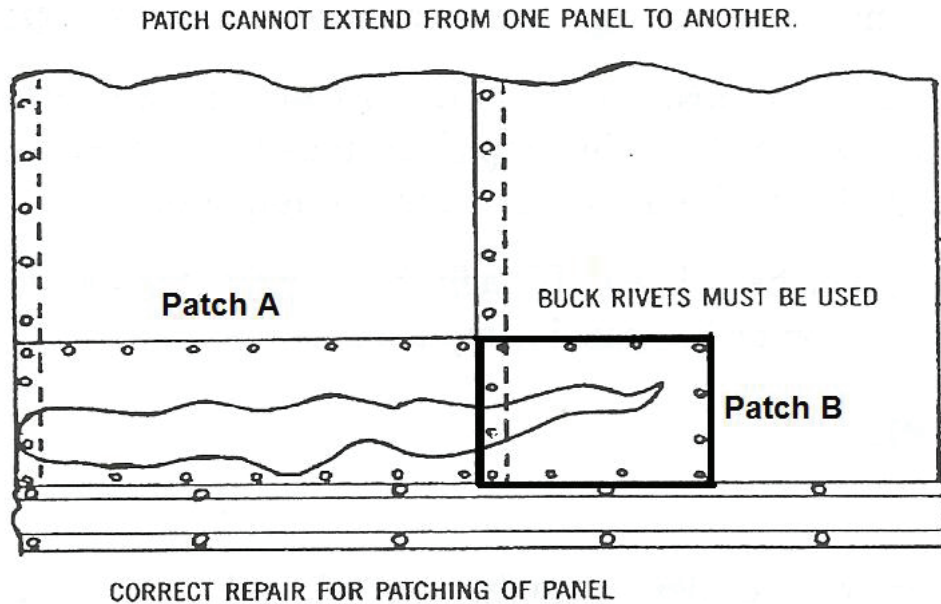

NOTE: No patch shall be less than 4" on any one side.

- (9) Cuts the full length of a single panel in the area of the top or bottom rail must be sectioned. Sections must be a minimum of 9 in. All sections must be buck riveted.

### c. Repairing Body Panel of Steel Container

Use of the correct type of steel, as well as proper surface preparation and painting methods, is critical.

#### (1) Straightening

Whenever possible, straighten dents and compression lines in panels by mechanical or hydraulic means without heating. It should not be necessary to use heat. Repairing a panel by straightening should return it to its original profile. If the damage has stretched the panel to such an extent that the original profile cannot be restored, repair by straightening should not be attempted.

#### (2) Straightening and Welding

To repair cracks, splits, cuts, tears, or pin holes when the original profile can be restored, straighten the damaged area: drill a stop hole at each end of any crack and weld the edges of the cut material to close the opening. Clean, mask, and prime the repaired area on both sides.

# AAR Intermodal Interchange Rules

## (3) Inserting

- (a) If the damage cannot be repaired by straightening, a butt-welded insert may be installed (see **Figure B-2**). Inserts may straddle an existing panel weld seam if the damaged area is on or near such a seam. Inserts may not be suitable if the damage covers a large area adjacent to a rail or post or if nearby inserts are corroded or improperly installed and must be corrected.

**Figure B-2 Panel Insert**

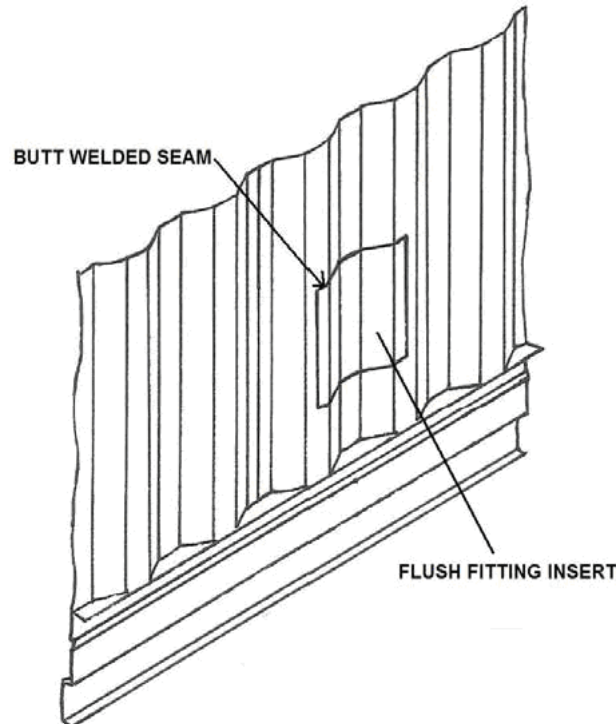

- (b) Remove any attachments (ventilators, marking plates, etc.) that are within the damaged area or near enough that they may be damaged during repair.
- (c) Mark and cut out the damaged area with a torch or cutting disc. Cut the replacement material to size. Inserts must be fitted flush with the existing panel and should be fabricated to allow no more than 2 mm (5/64 in.) clearance between adjoining surfaces. Panel insert material must have the same corrugation size, profile, and radii as the original panel.
- (d) Fit the insert into the cut-out area and tack-weld in position. Continuously weld the insert on the exterior side of the existing panels. Ensure that insert welds fully penetrate the panel to the interior side.
- (e) Clean, mask, and prime the repaired area on both exterior and interior sides. Apply top coat to the exterior side only.
- (f) Replace markings removed during repair that are required by regulation or as directed by the owner. Reattach any other components that were removed during the repair.

## AAR Intermodal Interchange Rules

### d. Overlay

- (1) If the damage cannot be repaired by straightening, an overlay may be installed. Overlay is the same as inserting, except that the replacement material is slightly larger than the material being removed, and edges overlap the original material. Patching may be substituted for inserting on body panels.
- (2) Remove any attachments (ventilators, marking plates, etc.) that are within the damaged area or near enough that they may be damaged during repair.
- (3) Mark and cut out the damaged area with a torch or cutting disc. Overlay should overlap the existing panel on the exterior by 1/2 in. In the case of corrugated panels, they should be fabricated oversize and must have the same corrugation size, profile, and radii as the original panel.
- (4) When installing the overlay, grind the existing panel to bare metal 3/4 in. from cut edges on the exterior side. This will provide a clean, smooth surface for the weld.
- (5) Fit the overlay into position over the cut-out area and tack-weld in position. Continuously weld the patch on the exterior side of the existing panels.
- (6) Clean, mask, and prime the repaired area on both exterior and interior sides. Apply top coat to the exterior side only. Apply sealant around entire perimeter of the cut-out hole covered by the overlay on the interior.
- (7) Replace markings removed during repair that are required by regulation or as directed by the owner. Reattach any other components that were removed during the repair.

### e. Panel Replacement of Sheet and Post Trailers and Containers

- (1) Sufficient panel lap is required to provide both a good seal and proper installation (see **Figure B-3**).

**Figure B-3 Panel Overlay**

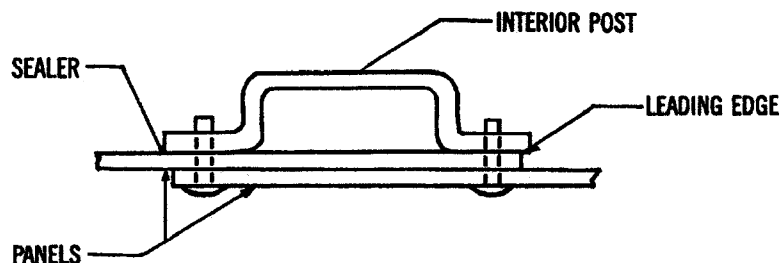

**Panels should overlay and be riveted as originally manufactured. See Section B-9 for proper riveting.**

- (2) Place the panel over the opening and drill around the panel perimeter, placing the holes on 1½ in. centers. If an existing rivet hole is used, it must be reamed to provide a tight fit by use of a larger size rivet.



## AAR Intermodal Interchange Rules

- (3) The placement area and existing adjacent panels must be cleaned and deburred where they lap.
- (4) Use applicable aluminum alloy or high tensile cadmium-plated steel rivets.
- (5) For securement of panels to posts to the trailer or container structure, buck rivets and/or structural mono bolts must be used. Self-sealing pop rivets may be used only at rail area where there is no rear access due to the trailer or container structure configuration.
- (6) A side post should never be spliced. If badly bent or cut, the interior post should be replaced before the section or full panel is replaced.

### f. Panel Assembly (Multiple Panels) Replacement

- (1) If damage to a side or front panel assembly cannot be repaired by straightening, inserting, or replacement of individual component panels, the entire panel assembly must be removed and replaced. Replacement of a panel assembly may also be performed if it is more economical than a series of lesser repairs to the individual panels. It is important to note that AAR dimensional tolerances can be affected when replacing the complete panel assembly. Dimensions must be checked before, during, and after the repair operation to ensure that AAR tolerances are maintained.
- (2) Remove any attachments (ventilators, marking plates, etc.) that are within the damaged area or near enough that they might be damaged during the repair process.
- (3) Measure the width and depth of the damaged panel corrugation to determine what size of material is required. Minor variations in the shape of the corrugations from the original panel are acceptable as long as the interior width of the container is not reduced.
- (4) Using a torch or disc cutter, cut the damaged panel away from the top and bottom rails and adjacent panels. Grind the cut areas smooth and clean.
- (5) The edges of the replacement panel should also be ground smooth and cleaned, ensuring that the replacement panel butts against the remaining panels. The gap between the replacement and remaining panels should not exceed 5/64 in.
- (6) Fit and tack-weld the replacement panels in position. The edges of replacement panels should butt together. Ensure that the lap at the corner post joints is a minimum of 1/2 in. wide.
- (7) Continuously weld the panels to the top and bottom rails, corner posts, and adjacent panels. Ensure full penetration to the interior of all butt welds. The interior seam of the corner post to panel lap joint should be skip-welded and sealed.
- (8) If the replacement panel assembly has not been blasted earlier, blast the panel to remove abrasive residue. Clean, mask, and prime the interior and exterior of the repaired area. Apply a top coat to the exterior.
- (9) Replace markings removed during repairs that are required by regulation or as directed by the owner. Reattach any other components that were removed during the repair.

## B4. Floors

### a. Floor Structure and Damage

- (1) The floor of a trailer or container is a key element of the structural system. In addition to the normal vertical loads, it carries longitudinal loads such as dock bumps, etc. The trailer or container floor consists of three main structural components that serve to support a fork lift and to transfer the load to the side panels. These components include the floorboards, crossmembers, and crossmember clips (crossmember-to-rail connectors).
- (2) If flooring requires repair, the method of repair should be the least aggressive necessary to correct the damage. The following is the general order of aggressiveness, from least to most:
  - (a) Cleaning
  - (b) Secure
  - (c) Dowel repair
  - (d) Sectioning or partial replacement
  - (e) Complete replacement
- (3) Floors in trailers or containers can be solid or laminated hardwood planks or plywood panels. All timber must be seasoned, with moisture content of less than 15% at time of installation.

# AAR Intermodal Interchange Rules

## b. General Repairs

- (1) Flooring replacements shall fasten to a minimum of three crossmembers. No adjacent flooring repairs shall end on the same crossmember; however, end joints must be staggered and sealed (**Figure B-4**).

**Figure B-4 Floor Repairs**

### FLOOR REPAIRS

The new floor section must be supported by a minimum of three crossmembers.

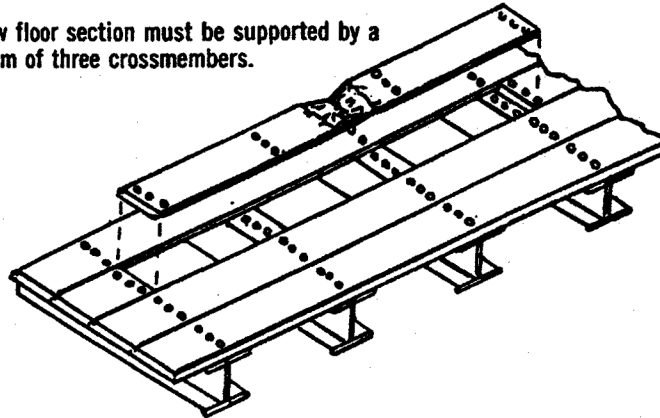

### NEW BOARD INSTALLATION

Install three 2" self-tapping flat screws at each cross-member covered by new board, three at butts.

### REMOVING DAMAGED FLOOR BOARD

New floor of the same section and material must be supported by three (3) crossmembers. Butts must fall at crossmember centerlines.

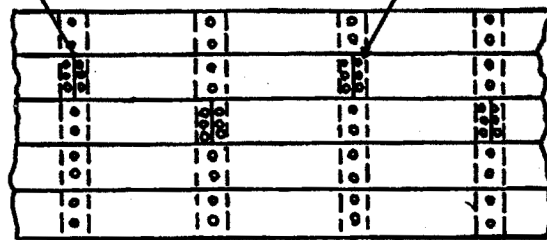

- (2) All repairs to flooring must be of similar quality and like installation as the original flooring, be free of visible defects, and be top-coated/undercoated.
- (3) Before starting repairs, it is recommended that an inspection of the crossmembers in the area of the board failure be made to determine if any crossmembers are in need of repair or replacement.

## c. Types of Repair (from Least to Most Aggressiveness)

### (1) Cleaning

Depending upon floor conditions, a floor may be cleaned by the following methods:

- (a) Sweeping (least aggressive)
- (b) Wash with water, detergent, or other cleaning agent
- (c) Steam-clean
- (d) Sanding (most aggressive)

### (2) Secure

- (a) Resecure loose fasteners
- (b) Replace broken or missing fasteners

### (3) Dowel Repairs

Holes up to 1/2 in. in diameter may be repaired by injecting a round hardwood dowel into the hole and securing it in place with glue. Hole should be smoothed, and dowel should be cut and smoothed to match the thickness of the floorboard.

- (a) Dowels must be round and made of hardwood.
- (b) Dowels cannot exceed 1/2 in. in diameter.
- (c) The minimum distance between the end of any floorboard, plank, or screw and any part of the dowel is 2 in.
- (d) The minimum distance from the side of a floorboard and any part of a dowel is one time (1X) the dowel diameter.
- (e) The minimum distance from any part of a dowel to any part of another dowel is four times (4X) the larger dowel diameter.

## AAR Intermodal Interchange Rules

### (4) Sectioning or Partial Replacement—Plank Floor

Proper repairs to a broken floor section are mandatory so that the integrity of the remaining floor is not affected by the repair. The following repair procedures must be followed:

- (a) From the point at which the damaged area stops, proceed in a forward and rearward direction at least one additional crossmember space, and mark the floor. Remove the floor screws in adjacent boards that will allow the damaged floor section to be raised above floor level, and cut the damaged boards at the points marked. Obtain an identical section, thickness, and variety of lumber for replacement.
- (b) Cut a section of the replacement lumber to a length compatible with the removed material. Apply sealant to the mating perimeter edges of the floorboard, and lay in place, ensuring that the joint between adjacent boards interlocks. Sealant exposed to cargo-carrying surfaces should not be of butyl material, but rather of urethane or chloroprene material suitable for contact with cargo.
- (c) Reinstall any missing fasteners in adjacent boards, and drill a minimum of three holes through the new board plank at each crossmember location. Install 2 in. long self-tapping flat-head screws at each location.
- (d) Install a bead of sealant across the butt joint between the new and adjacent floor planks to ensure against leakage.
- (e) In situations where extensive damage is done to a floor and more than one floor board is damaged, be sure to install replacement planks so that no two adjacent butt joint conditions exist at any one crossmember. If necessary, stagger the joints by installing longer-than-required floor replacement inserts at adjacent positions. This is extremely important. Any distortion that results in the lack of contact between the floor and the crossmember can be remedied by reinstalling screws through the floor and positioning nuts on the bottom shank of the screw, thereby clamping the floor and crossmember together.
- (f) The butt gap between boards shall not exceed 1/4 in.

### (5) Sectioning or Partial Replacement—Plywood Floor

- (a) Replacement plywood sections must extend from bottom rail to steel center support. If a center support is not present, one must be installed.
- (b) Longitudinally laid replacement boards must be cut so that joints with existing adjacent boards lie over the center of the top flange of a crossmember or outrigger.
- (c) Transversely laid boards must be as wide (in the longitudinal direction) as the original board.
- (d) Half of the original panel, approximately 4 ft × 4 ft, must be replaced.
- (e) The longitudinal butt joint between the original and replacement panel must be along the centerline of the container.
- (f) If original floor was coated by the manufacturer, apply coating to the new wood and to adjacent areas where coating was disturbed.

## AAR Intermodal Interchange Rules

(g) Apply sealant along mating edges of new plywood section.

### (6) Complete Replacement—Plank Floor

(a) Follow procedures described in Sectioning or Partial Replacement—Plank Floor.

(b) When fitting the planks into place, insert wedges between the bottom side rails and the adjacent floor plank to ensure that the planks fit tightly.

### (7) Complete Replacement—Plywood Floor

(a) Follow procedures described in Sectioning or Partial Replacement—Plywood Floor.

(b) If a plywood floor without a center support is being replaced, a center support must be installed before the flooring is fitted.

#### d. Side Liners

(1) Repair/replacement materials shall be the same quality, type, and thickness as the original liner material.

(2) The installation of ply-liners should use the same type fasteners as used in the original installation.

(3) If a ply-liner has a hole greater than 4 in., the ply-liner should be replaced.

#### e. Scuff Liner

The scuff liner and fasteners must be of like material as the original installation. Sectioning is acceptable, with end joints located at a side post.

#### f. Roof

If the trailer or container is equipped with a plywood liner, replacement must be of the same quality, type, and thickness as the original. (See B6, Roof Repairs, for specific roof repairs.)

## B5. Trailer or Chassis Support Repairs

### a. Landing Legs

#### (1) Description

The landing leg system (see **Figure B-5** and **Figure B-6**) has been designed to provide a stable support for the trailer or chassis and is located from centerline of the kingpin.

Manually operated landing gears must be of two speeds, and the legs must be equipped with heavy-duty wheels and/or pads and heavy-duty axles.

# AAR Intermodal Interchange Rules

Figure B-5 Leg Assembly, Driver

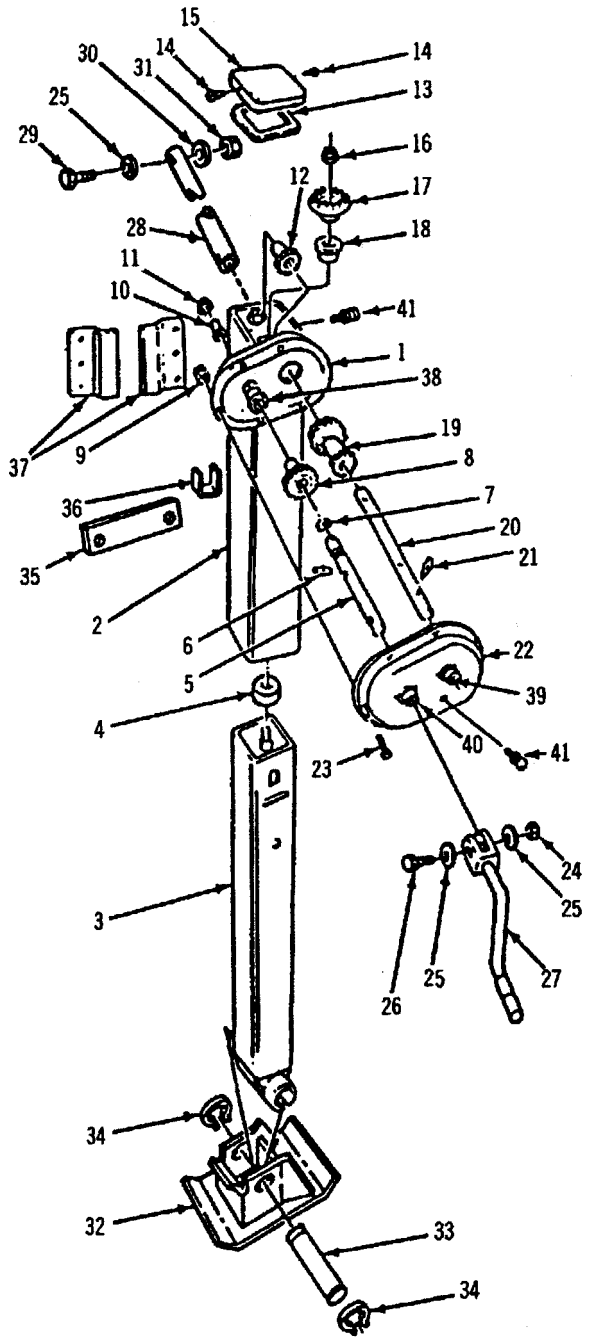

Index No.	Description
1	Pan Assy, Inner Housing
2	Leg Assy, Outer Support
3	Inner Leg Tube Assy
4	Bearing, Thrust
5	Crankshaft
6	Cross Pin
7	Detent, Spring
8	Gear, Crankshaft Cluster
9	Nut, Hex
10	Dust Cover
11	Clamp, Dust Cover
12	Pinion, Bevel
13	Gasket, Support Cover
14	Screw
15	Cover Support Leg
16	Lock Nut
17	Gear, Bevel
18	Bearing, Bevel Gear
19	Gear, Mainshaft Cluster
20	Mainshaft
21	Cross Pin
22	Pan Assy, Outer Housing
23	Bolt, Hex
24	Nut, Hex
25	Washer
26	Bolt, Hex
27	Crank, Support
28	Shaft, Cross
29	Bolt, Shoulder
30	Washer
31	Nut, Hex
32	Sand Shoe Assy
33	Tube, Axle
34	Retaining Ring
35	Plate, Mounting (Lug)
36	Clip/Crank Handle Retaining
37	Mounting Bracket
38	Bushing
39	Bushing, Mainshaft
40	Bushing, Crankshaft
41	Fitting Lubrication
42	Standard Sand Shoe
43	Low-Profile Sand Shoe

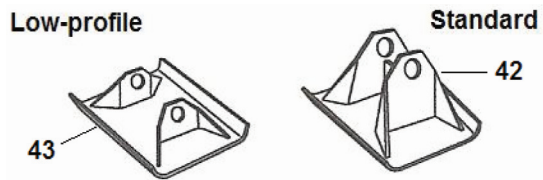

# AAR Intermodal Interchange Rules

### Figure B-6 Support Frames and Supports

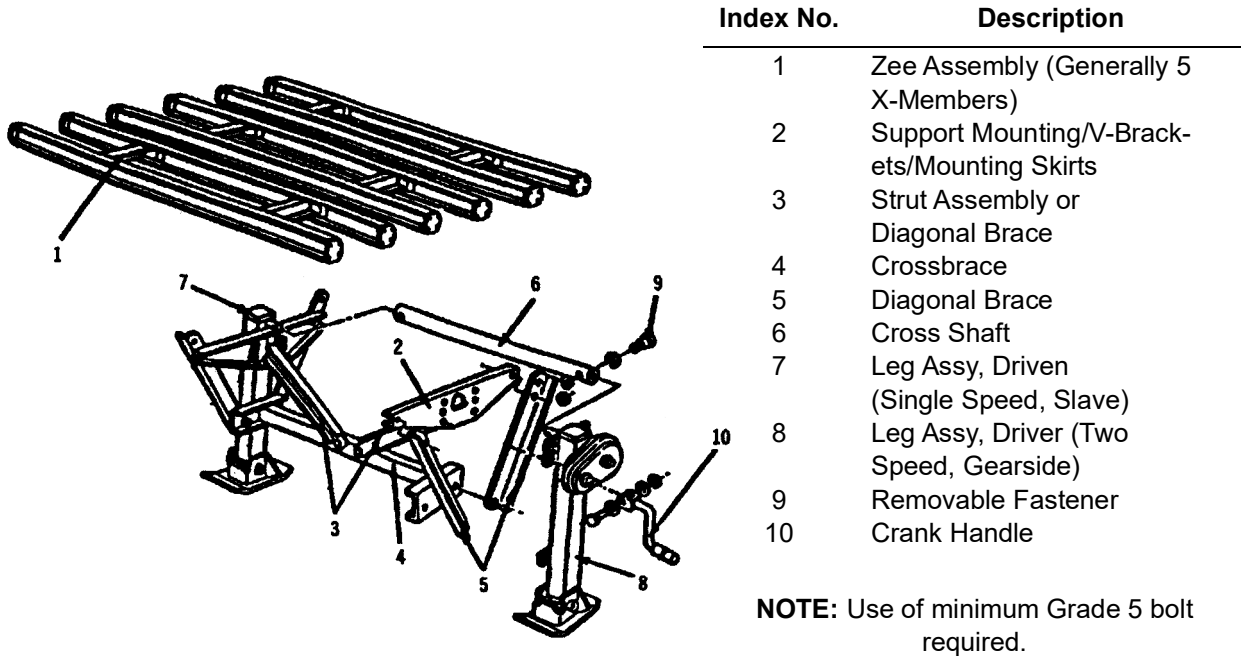

### (2) Defects

When a landing gear lower leg and/or upper leg assembly is bent, damaged, or deformed to a point that will not allow free vertical travel, the leg(s) should be replaced.

The normal defects associated with non-functional landing gear are:

- (a) Broken welds
- (b) Loose fasteners (missing, broken, defective, or improper materials)
- (c) Legs improperly adjusted
- (d) Defective components (bent or broken)
- (e) Dry or insufficient lubricant

### (3) Repair Comparability Required

- (a) If other than the original type legs are installed, the bolt patterns, gear ratio, and load rating must be compatible.
- (b) Landing leg braces that have been bent or damaged should be straightened, if practical, or replaced, if necessary, with a new one of like kind or equal strength to the original.



## AAR Intermodal Interchange Rules

### (4) Component Replacement vs. Leg Replacement

When a landing leg is defective due to internal component failure without damage to the leg assembly, the components should be replaced, if necessary, in lieu of replacing the entire leg. Reassembly must include proper lubrication.

### (5) Landing Gear Mounting Bracket

If damage to the landing gear mounting bracket is such that it is impractical to repair and it must be replaced, the replacement bracket must be of like kind as original equipment. The bolt-on type requires a direct one-for-one replacement, utilizing identical fastener patterns and sizes as the original installation.

(a) In replacing the weld-on bracket, care must be taken to remove the damaged bracket without distorting, bending, or cutting through mounting surfaces adjacent to the bracket. If this is not possible, crossmembers directly over the landing gear must also be replaced with the bracket.

(b) Mounting brackets must be attached as established on original equipment.

### (6) Sand Shoes, Dolly Wheels, and Axles

When is it necessary to replace sand shoes, dolly wheels, and/or axles, the replacement must be of like size, shape, and strength as the opposite position and must be properly secured.

### (7) Landing Gear Crank Handle

When it is necessary to replace the landing gear crank handle, the replacement must be of sufficient size and shape to clear the side of trailer or container and must store in existing storage retainer.

### (8) Cross Shaft

When it is necessary to replace the cross shaft, the replacement must be of the same size, shape, and strength as that of the original equipment. A removable fastener must be used in installation.

## B6. Roof Repairs

### a. General Repairs

Roof repairs (see **Figure B-7**) are equally, if not more, important than repairs to the nose or side walls of a trailer or container. Correct materials and good workmanship can determine if there will be load damage caused by weather. Roof panels that have a tear or hole should be repaired to prevent structural failure and water damage to cargo. Generally, repairs consist of a relatively simple patch or replacing a section of roof panel the full width of the trailer or container, extending to the nearest roof bows adjacent to the damaged area. Certain procedures must, therefore, be followed when roof repairs are made.

# AAR Intermodal Interchange Rules

### Figure B-7 Roof Sheet Edge Treatment

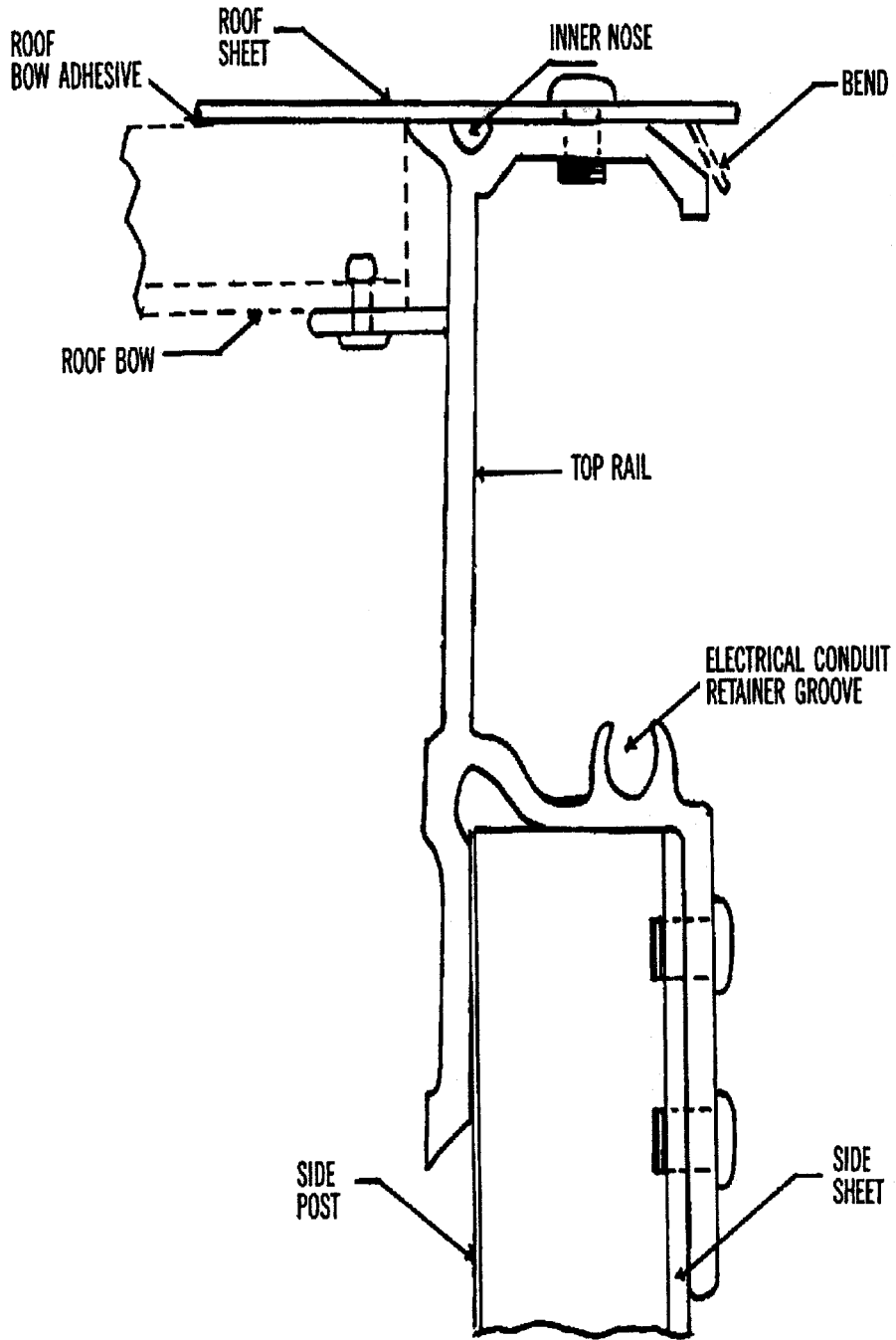

## AAR Intermodal Interchange Rules

### b. Roof Patching—Aluminum

- (1) Care must be exercised to ensure that roof repairs are properly extended to the roof bows and given a good exterior seal to afford maximum long life to the repair and to avoid loosening of roof sheet by flexing. Patch is not to be riveted through the roof bow.
- (2) For small repairs, a patch shall be made to overlap the existing panel break of not less than 1 in. on all sides. On larger breaks, the damaged portion must be trimmed to produce a round or oblong opening (same as side panels). No patch shall be less than 4 in. on any one side.
  - (a) Aluminum and steel patches shall be the same thickness and type as original roof sheet.
  - (b) Clean and deburr both panel and patch. Smooth any dented or creased area around damage.
  - (c) Placing the patch over the break, drill holes for rivet securement around the patch perimeter, spaced on 1½ in. centers. Rivet holes shall be located not less than ½ in. from the edges of the patch.
  - (d) Any roof bow damage shall be repaired prior to the application of the patch.
  - (e) Apply a sealer between the patch and roof sheet and around the edge of patch, with additional sealer placed over the exterior rivet heads.
  - (f) Roof patches must be secured with soft buck rivets to prevent flexing and rivet hole elongation. Where the underside of the roof is inaccessible, repairs must be made with self-sealing pop rivets. All roof bow repairs or replacements must be made with original type fasteners or two-piece rivets.
  - (g) Holes must be drilled in the leading ends of any stress crack.
  - (h) When the patch extends to the top rail, buck rivets must be used.

### c. Roof Sheet Breaks More than 6 in.

Sections on roof sheet breaks in excess of 6 in. shall extend to and be secured adjacent to roof bows. If the trailer or container is so constructed, the section applied must be bonded to roof bows.

- (1) If damage requires removal of original roofing from the top rail, the entire original roof sheet must be sectioned and replaced to the nearest end.
- (2) If the roof has been previously sectioned in the area of damage, the new section must be extended beyond the previous section.
- (3) Roof patch cannot exceed 12 in. × 36 in.
- (4) If the area to be sectioned exceeds 30% of the roof, the entire roof must be replaced.
- (5) No more than two sections shall make up the entire roof of a trailer. The center of the roof sheet cannot be spliced.

## AAR Intermodal Interchange Rules

### d. Roof Replacement—Aluminum

- (1) A one-piece aluminum sheet must be used for trailers.
- (2) All damaged roof bows must be removed and replaced with new roof bows and secured at each end to the top rail by use of huck-type fasteners or manufacturer's original-type fasteners.
- (3) After removal of the old roof sheet or container roof segment and subsequent to any roof bow replacement, all roof bows and rail gutters must be cleaned and deburred.
- (4) Before installing new roof, apply a sealer on the roof rail or in the roof rail gutter around the entire trailer or container.
  - (a) Trailer—Roof replacement extends from noserail to rear header
  - (b) Container—Roof segments consist of front (noserail to intermediate header), center (intermediate header to intermediate header), rear (intermediate header to rear header).
- (5) The roof sheet must be secured to the front rail for trailer, and either the front rail or intermediate header for container, spaced as recommended by the manufacturer.
- (6) The trailer or container must be on a level ground surface when a new roof is applied. The new roof sheet must be stretched in place by using clamps or roof stretchers at the rear header of the trailer or container, or intermediate header for container. (This phase is very important to reduce the possibility of roof sheet flapping, which could cause flex cracking.)
- (7) The sides of the new roof sheet must be affixed to the top rails and rear headers and/or intermediate header for containers according to the manufacturer's specification.

### e. Roof Bows

Roof bows that are broken or missing should be replaced. Due to the wide variety of designs, the original trailer or container manufacturer should be consulted for its recommendations on bow replacements.

### f. Corrugated Steel Roof

- (1) Container roof is made of self-supporting corrugated panels.
- (2) Bends may be straightened without heating by using a jack, along with a flat hammer or mallet.
- (3) To repair cracks, cuts, or holes when the original profile can be restored, straighten the damaged area. Drill stop holes at each end of any crack. Weld edges of the cut/cracked material. Clean, mask, prime, and top-coat the repaired area.

## AAR Intermodal Interchange Rules

- (4) If the damage cannot be repaired by straightening and welding, an insert or patch may be installed. Steel insert/patches shall be the same thickness and type as original roof panel.

### (a) Inserting

- 1) If the damage cannot be repaired by straightening, a butt-welded insert may be installed. Inserts may straddle an existing panel weld seam if the damaged area is on or near such a seam. Inserts may not be suitable if the damage covers a large area adjacent to a rail or post or if nearby inserts are corroded or improperly installed and must be corrected.
- 2) Mark and cut out the damaged area with a torch or cutting disc. Straight cuts are important when inserts are installed. Cut the replacement material to size. Inserts must be fitted flush with the existing panel and should be fabricated to allow no more than 2 mm (5/64 in.) clearance between adjoining surfaces. Panel insert material must have the same corrugation size, profile, and radii as the original panel.
- 3) Fit the insert into the cut-out area and tack-weld in position. Continuously weld the insert on the exterior side of the existing panels. Ensure that insert welds fully penetrate the panel to the interior side.
- 4) Clean, mask, and prime the repaired area on both exterior and interior sides. Apply top coat to the exterior side only.

### (b) Overlay

- 1) If the damage cannot be repaired by straightening, an overlay may be installed. Overlay is the same as inserting, except that the replacement material is slightly larger than the material being removed, and edges overlap the original material. Overlay may be substituted for inserting.
- 2) Mark and cut out the damaged area with a torch or cutting disc. Overlays should overlap the existing panel on the exterior by 1/2 in. In the case of corrugated panels, they should be fabricated oversize and must have the same corrugation size, profile, and radii as the original panel.
- 3) When installing the overlay, grind the existing panel to bare metal 3/4 in. from cut edges on the exterior side. This will provide a clean, smooth surface for the weld.
- 4) Fit the overlay into position over the cut-out area and tack-weld in position. Continuously weld the patch on the exterior side of the existing panels.
- 5) Clean, mask, and prime the repaired area on both exterior and interior sides. Apply top coat to the exterior side only. Apply sealant around entire perimeter of the cut-out hole covered by the overlay on the interior.

## AAR Intermodal Interchange Rules

### (c) Replacement

- 1) It is important to note that AAR dimensional tolerances can be affected when replacing the complete roof assembly. Dimensions must be checked before, during, and after the repair operation to ensure that AAR tolerances are maintained.
- 2) Using a torch or cutting disc, remove the roof sheet from the top rails, taking care to ensure that the rail is not damaged. Another option is to cut roof sheet inside the top rails, leaving a strip attached to rail. Remove the strip from the rails by grinding away the weld seam with a disc grinder.
- 3) Place the replacement panels in position. Tack-weld panels in position, check alignment is correct, and then continuously weld in place. For butt joints, the gap between the replacement panels should not exceed 5/64 in.
- 4) Clean, mask, and prime the interior and exterior of the repaired area. Apply a top coat to the exterior only.

### B7. General Repair Policy for Corner Posts

- a. Damage to corner posts can be repaired by straightening, inserting, or complete replacement. No full-profile sectioning of any kind is allowed on front corner posts.
- b. Whenever possible, damage should be corrected with straightening by hydraulic or mechanical means without heat. Heat may be used only when the corner post cannot be straightened without heating. If heat must be applied, the steel should be heated only in the damaged area and must not be heated beyond a dull cherry-red color: approximately 650 °F, or a 650 °F temperature-indicating heat stick.
  - (1) Damage to corner posts that cannot be repaired by straightening can be repaired by installing an insert.
  - (2) A maximum of two inserts (check specific manufacturer's recommendations) are allowed in a front corner post provided all of the following limitations are followed:
    - (a) There are no maximum height limitations for front corner post inserts. Full-height front corner inserts are acceptable.
    - (b) When two inserts share a common weld, the total length of the horizontal plane of the common weld must not extend through more than half of the external cross-sectional profile of the post.
    - (c) Inserts must be fitted flush with the original material and butt-welded.
    - (d) Front corner post inserts may be rectangular, oval, or diamond shaped.
    - (e) No insert may share the same horizontal plane as another insert.
    - (f) Inserts must be a minimum of 6 in. in length and must extend through at least 3 in. of the cross-sectional profile of the post.

# AAR Intermodal Interchange Rules

- (g) An insert that would terminate within 6 in. of an existing insert must be extended to that insert to form a common weld.
- (h) A front corner post insert that would terminate within 12 in. of a corner fitting must be extended to the fitting and must be at least 12 in. in length.

**Figure B-8 Improper Repairs to Corner Posts**

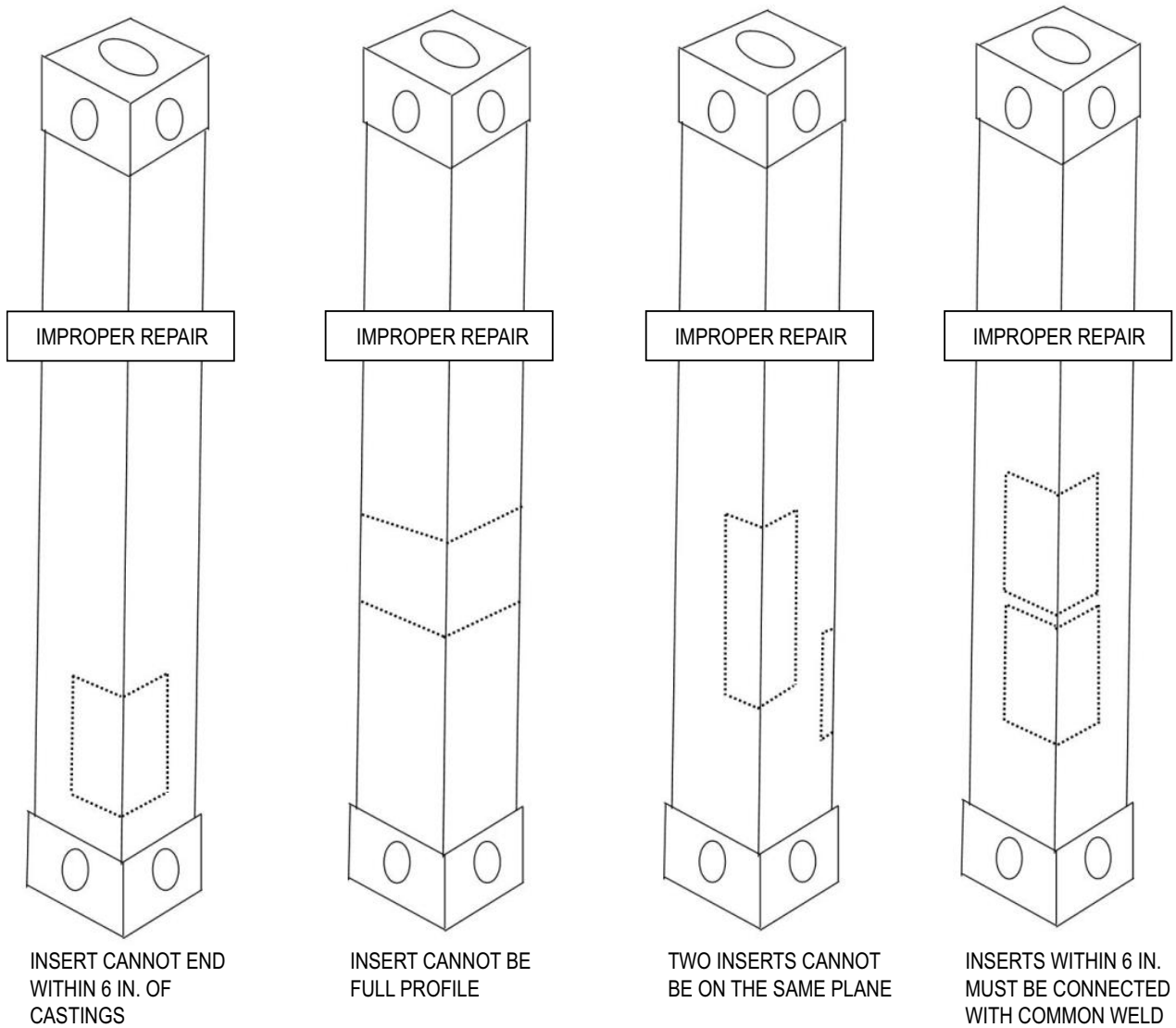

# AAR Intermodal Interchange Rules

## Figure B-9 Correct Repairs to Corner Posts

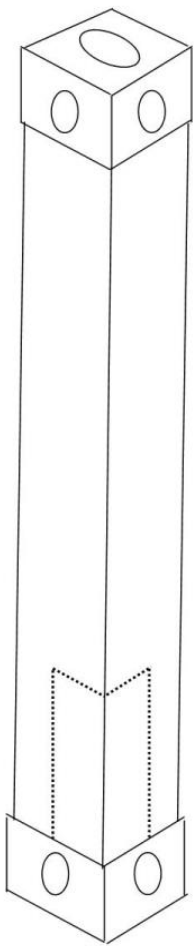

INSERT THAT WOULD END WITHIN 12 IN. OF CASTING MUST EXTEND TO CASING AND BE AT LEAST 12 IN. IN LENGTH

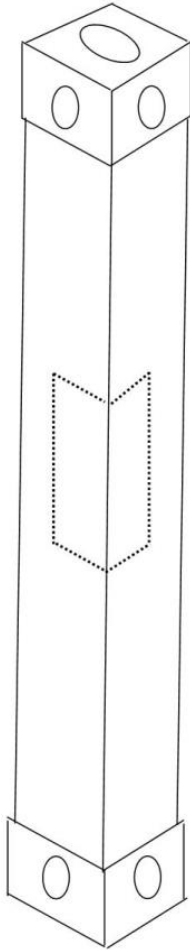

INSERTS MUST BE A MINIMUM OF 6 IN. AND EXTEND THROUGH AT LEAST 3 IN. OF CROSS-SECTIONAL PROFILE

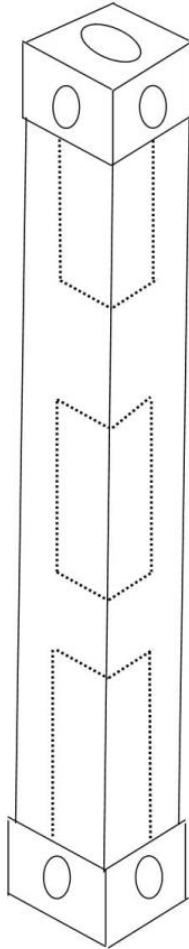

INSERTS MUST BE A MINIMUM OF 6 IN. APART

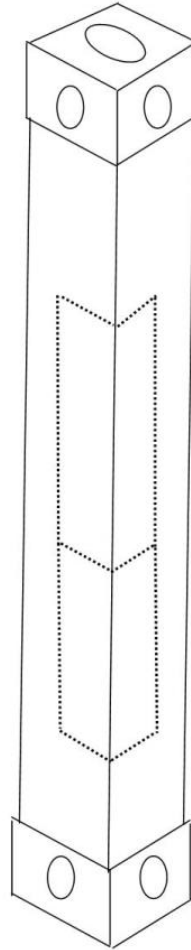

INSERT THAT WOULD TERMINATE WITHIN 6 IN. OF AN EXISTING INSERT MUST BE EXTENDED TO THAT INSERT TO FORM A COMMON WELD.

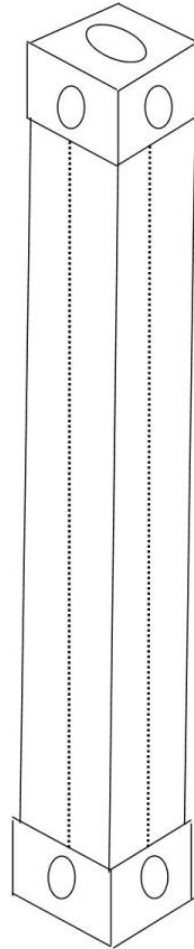

FULL HEIGHT FRONT CORNER INSERTS ARE ACCEPTABLE



# AAR Intermodal Interchange Rules

## B8. Rear Doors and Rear Frame

### a. General

The rear doors (see **Figure B-10**) are probably the most damaged component on an intermodal trailer or container; therefore, certain repair procedures must be followed to maintain the overall structural integrity of the trailer or container.

**Figure B-10 Rear Door Assembly**

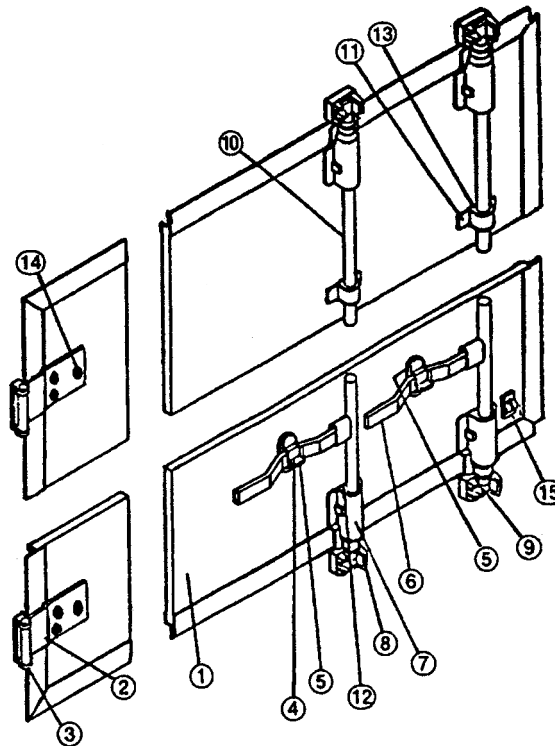

Index No.	Description
1	Plymetal Door – 1¼"
2	Hinge Strap/Butt
3	Hinge Pin
4/5	Seal Pin (Handle Latch) Assy.
6	Door Handle
7	Upper/Lower Rod Guide
8	Upper/Lower Cam Keeper
9	Upper/Lower Cam
10	Lock Rod Pipe
11	Intermediate Rod Guide
12	Upper/Lower Rod Guide
13	Intermediate Rod Guide Bushing
14	Fastener
15	Door Tie Back Plate

## AAR Intermodal Interchange Rules

The door of a trailer or container is designed so that when loaded beyond the design load, failure will take place in the door locking hardware and not in the connections between the end frame (see **Figure B-11**) and the trailer or container body. The door and assembly are designed to withstand the maximum loads and fatigue forces imposed in rail operation. (Generally, the door end assembly consists of the door frame, doors, door hinges, door locking hardware, and the attachment of these items.)

**Figure B-11 Rear Frame Assembly**

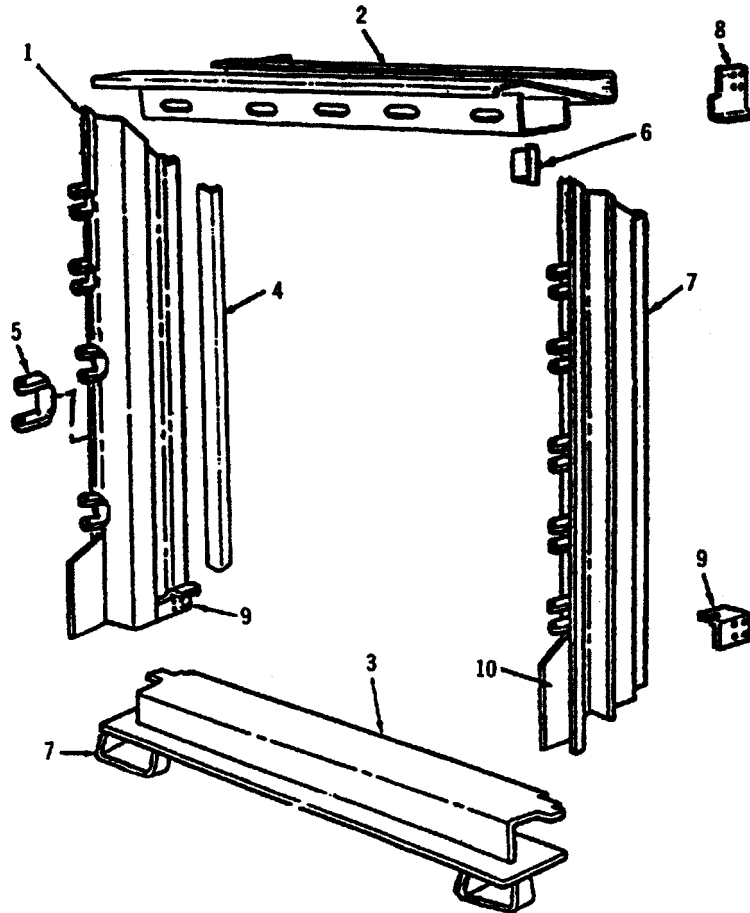

Index No.	Description
1	Post, Rear Corner, Roadside & Curbside 12' Lights
2	Header Assembly
3	Crossmember Assembly
4	Angle, Plywood Edge Protector
5	Hinge, Bracket
6	Bumper, Curb/Roadside
7	Light Protector
8	Upper Tie Plate, Roadside & Curbside
9	Lower Tie Plate, Roadside & Curbside
10	Bumper, Lower

# AAR Intermodal Interchange Rules

## b. Repair Procedures

### (1) Rear Doors

- (a) Plating of rear doors is not permitted and shall not be considered a proper repair (except as *only* a temporary repair). Self-sealing patches are allowable on cuts that do not extend more than 1/8 in. into the door plywood.
- (b) All door replacements shall be made with like materials (gaskets, door hardware, door dimensions).
- (c) When doors are mounted, they shall be mounted flush with the door frame and shall be constructed such that the curbside door must be opened before the roadside door can be opened.
- (d) All decals and signs shall be replaced on new doors.
- (e) The replacement of all tie-backs on new doors is required.

### (2) Security Hardware

- (a) Lock rods and hinge plates shall meet AAR M-931 specifications.
- (b) When doors are replaced, the security plate must be replaced.
- (c) All door-seal locking devices, door securement hardware, and door attachment hardware must be affixed by fully welding or by the use of “tamper-proof” fasteners to preclude entry into the trailer or container by removal of any of the door hardware components. A minimum of one fastener on each of the top and bottom hinges and top and bottom lock-rod support bearings shall be “tamper-proof.” All door seal hasp fasteners also shall be “tamper-proof.”
  - 1) Fasteners may be considered “tamper-proof” by virtue of their original design or because of alteration to reusable fasteners, which requires their destruction by burning or cutting to effect removal. Reusable fasteners, such as nuts and bolts, are not recommended; if used, they must be secured by fully welding the nut to the bolt or the bolt to its mating hardware. (Fully welding means welding around the entire circumference of the bolt.) Prevailing-torque fasteners utilizing deformed threads or plastic inserts are not considered as “tamper proof” fasteners (except when they are inaccessible, such as on refrigerated trailer doors). Tack or spot welding is not permissible.
- (d) All door hardware shall have a hot-dip galvanized finish or functional equivalent.

## (3) Rear Door Frame

- (a) Rear door headers are designed to protect all lights and wiring from mechanical damage during normal operations.
- (b) Rear door lower sills are designed to protect lights, reflective lenses, and door lock keepers from mechanical damage during normal operations, as typified by backing into loading platforms and railcar bridge plates rubbing against the trailer during transit. Replacement rubber or fabric-type bumpers do not meet this requirement.

## B9. Splicing of Side Rails

### a. Repair Procedures

Damages to the top or bottom rails will directly affect the overall integrity of the trailer or container and if not properly handled, could cause the total failure of the equipment. The following considerations are involved with this type of repair (see **Figure B-12**, **Figure B-16**, and **Figure B-17**):

- (1) Manufacturer's recommendations for repairs to top or bottom rail must be followed, with all splices adding adequate strength to the damaged area.
- (2) No more than one splice per rail is allowed.

### b. Aluminum Trailers

- (1) A spliced rail section shall not exceed 25% of the overall vehicle length. (Refer to **Figure B-12**)
- (2) Splice plates must be of steel and/or aluminum; insulating tape must be used between the aluminum and steel components.
- (3) The bottom rail splice plate must extend a minimum of three crossmembers, and the top rail splice plate must span a minimum of two posts.
- (4) Splice plates on the top rail (per manufacturer specifications) can be installed on either the interior or exterior of the rail.
- (5) When a rivet is replaced with a bolt in a crossmember, it must have a minimum of at least a Grade 5 bolt with a self-locking nut. Lock washers may *never* be used.
- (6) The welding or plating of top or bottom rails as a means of a repair is prohibited if it directly affects the strength and/or integrity of the rail.

## AAR Intermodal Interchange Rules

Figure B-12 “Rule of Thumb” for Trailer Splicing

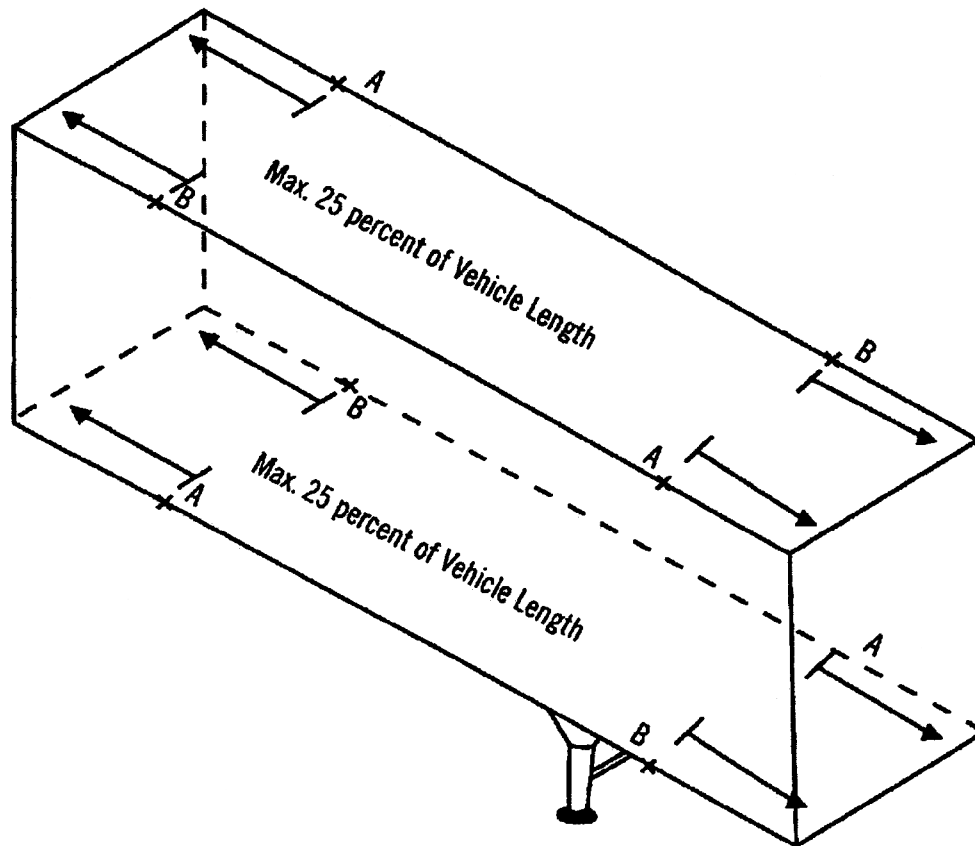

If splice(s) exist(s) at any A location, then splice is permitted at any other A location(s). If splice(s) exist(s) at any B location, then splice is permitted at any other B location(s). Neither A location may be spliced if either B location on the same side is spliced. Neither B location may be spliced if either A location on the same side is spliced.

## AAR Intermodal Interchange Rules

### c. Aluminum Containers

- (1) If splice(s) exist(s) at any A location, then splice is permitted at any other A location(s). If splice(s) exist(s) at any B location, then splice is permitted at any other B location(s). Neither A location may be spliced if either B location on the same side is spliced. Neither B location may be spliced if either A location on the same side is spliced. See **Figure B-13** for A and B locations.

**Figure B-13 Splicing Bottom and Top Rails**

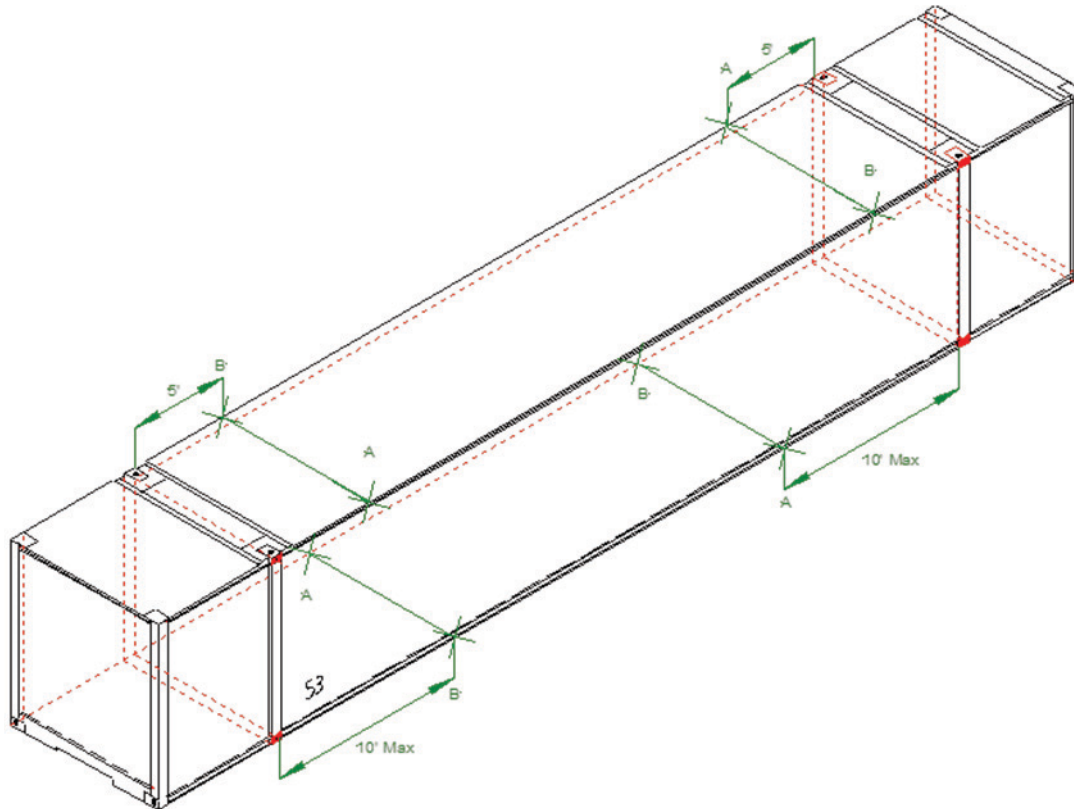

- (2) Top rail: No splice may be inserted farther than 5 ft from either stacking post.
- (3) Bottom rail: No splice may be inserted farther than 10 ft from either stacking post.
- (4) Splice plates must be of steel and/or aluminum. Insulating tape must be used between the aluminum and steel components.
- (5) The bottom rail splice plate must extend a minimum of three crossmembers, and the top rail splice plate must span a minimum of two posts.
- (6) Splice plates on the top rail (per manufacturer's specifications) may be installed on either the interior or exterior of the rail.
- (7) When a rivet is replaced with a bolt in a crossmember, it must have a minimum Grade 5 bolt with a self-locking nut. Lock washers may never be used.

## AAR Intermodal Interchange Rules

- (8) Top rail: Lip or flange of the top rail may be repaired up to 12 in. by installing an angle as needed to fit cut-out in the upper rail. When damage is larger than 12 in., a section or rail replacement may be required.
- (9) The welding or plating of top or bottom rails as a means of a repair is prohibited.
- (10) Bottom rail: Overlay (plating)—see manufacturer's recommendations.  
(Reference—Stoughton's lower rail plating recommendations for minor damage)

### d. Steel Containers

- (1) Straighten damaged bottom rails and top rails whenever possible. Straighten any dents or other distortions to the component by hydraulic or mechanical means without heat. If heat must be applied, the steel should be heated only in the damaged area and must not be heated beyond a dull cherry-red color: approximately 650 °F, or a 650 °F temperature-indicating heat stick.
- (2) Whatever method is used must not adversely affect the structural integrity of the component nor restrict its safe operation.
- (3) Welding or straightening and welding of cuts in a component or in a weld joining components can, in many cases, be repaired by welding or a combination of straightening and welding. Straighten the damaged area, if necessary, to restore original profile. Drill stop holes at each end of the cut. Weld the edges of the cut material, then clean, prime, and top-coat according to manufacturer's specifications.
- (4) Damage to steel rails that cannot be repaired by straightening or welding can be repaired by installing an insert.
  - (a) Determine the length of the original component to be removed. Mark where the cuts are to be made and shield or temporarily remove any nearby wooden components to protect against burning damage. Remove the damaged area by flame-cutting with an oxygen-acetylene torch, disc grinding, or other methods.
  - (b) Straighten the remaining edges of the adjoining area. Clean smooth all cut edges with a grinding disc.
  - (c) Cut to size and clean the replacement insert. The replacement material must have the same profile as the original and be of the same or higher quality, strength, and thickness. Inserts must be fitted flush with the existing component and should be fabricated to allow no more than 5/64 in. clearance between adjoining surfaces.
  - (d) Tack-weld in position, check alignment, and continuously weld the insert on the exterior. Ensure that the insert welds fully penetrate the panel to the interior side.
  - (e) Reinstall any temporarily detached components, and remove any shielding used during repair.
  - (f) Clean, mask, prime, and top-coat the repaired area.

## AAR Intermodal Interchange Rules

- (5) Damage to a top rail that cannot be repaired by straightening or installing an insert may be repaired by replacing the damaged section of rail. When installing a replacement section, the entire cross-section profile of the rail must be removed.

**Figure B-14 Not Acceptable and Acceptable Rails**

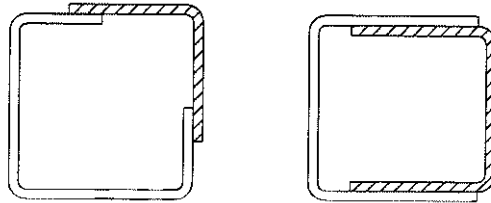

INSERTS NOT FLUSH WITH REMAINING RAIL  
NOT ACCEPTABLE

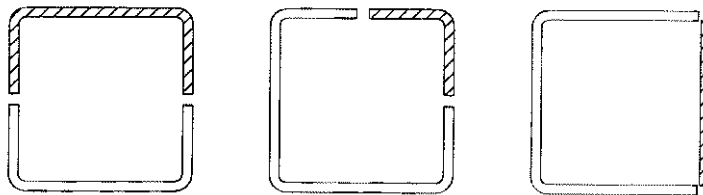

ACCEPTABLE

- (a) Sections must be a minimum of 6 in. and cannot end within 12 in. of a casting. Any section welded to a casting must be a minimum of 12 in. For repair steps, see Rule B9.d.(4)(a) through (f).



# AAR Intermodal Interchange Rules

- (6) Damage to a bottom rail that cannot be repaired by straightening or installing an insert may be repaired by replacing the damaged section of rail. When installing a replacement section, the entire cross-section profile of the rail must be removed. For repair steps, see Rule B9.d.(4)(a) through (f).

**Figure B-15 Acceptable Bottom Rail Inserts**

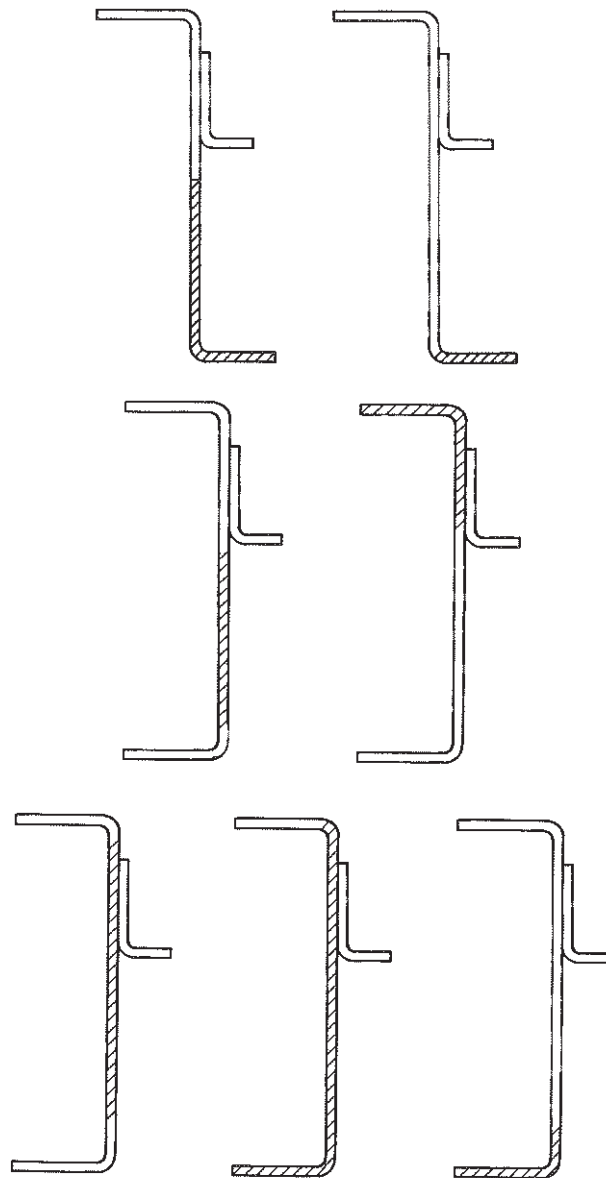

# AAR Intermodal Interchange Rules

## e. Definitions

### (1) Top Rail Protectors

Top rail protectors are non-structural attachments at side rails, located near the top side, to protect the top rails and roof from contact with lift arms of lifting devices.

The bearing surface of top rail protectors is designed so as to prevent any contact of the lift arms of lifting devices with the trailer top rails or roof.

Top rail protectors are fastened to the trailer in a manner that prevents damage of top rail protector attachments by lift arms of lifting devices.

### (2) Lift Pads (Bottom Rail Protectors)

Lift pads are non-structural attachments at bottom side rails to protect crossmembers, bottom side rails, side walls, and mechanical fasteners located near the bottom of the side and beneath the body from contact with lift shoes of lifting devices.

- (a) The horizontal bearing surface of lift pads shall extend inwardly from the outside vertical plane of the body a minimum of 6 in. The vertical bearing surface shall extend upward from the bottom side rail a minimum of 2¼ in. See **Figure B-15a**.
- (b) Lift pads are fastened to the trailer in a manner that prevents damage of lift pad fasteners by lift shoes of lifting machines.

**Figure B-15a Trailer Lift Pads (Bottom Rail Protectors)**

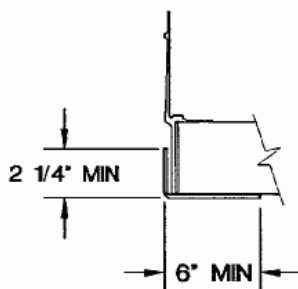
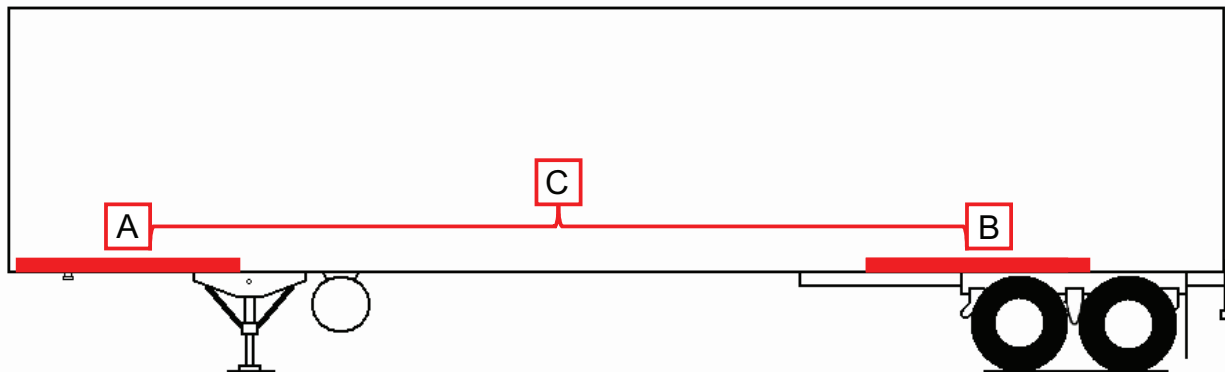

Note	Description	28 ft	45 ft	48 ft and Longer
A	Front lift pad	Minimum 5 ft in length	Minimum 10 ft in length	
		The entire lift pad should be placed forward of the landing gear.		
B	Rear lift pad	Minimum 5 ft in length	Minimum 10 ft in length	
		The front edge of the rear lift pad should not be placed forward of the sliding tandem assembly.		
C	Centerline distance between lift pads	15 ft	30 ft	35 ft

# AAR Intermodal Interchange Rules

## Figure B-16 Splicing of Top Rails

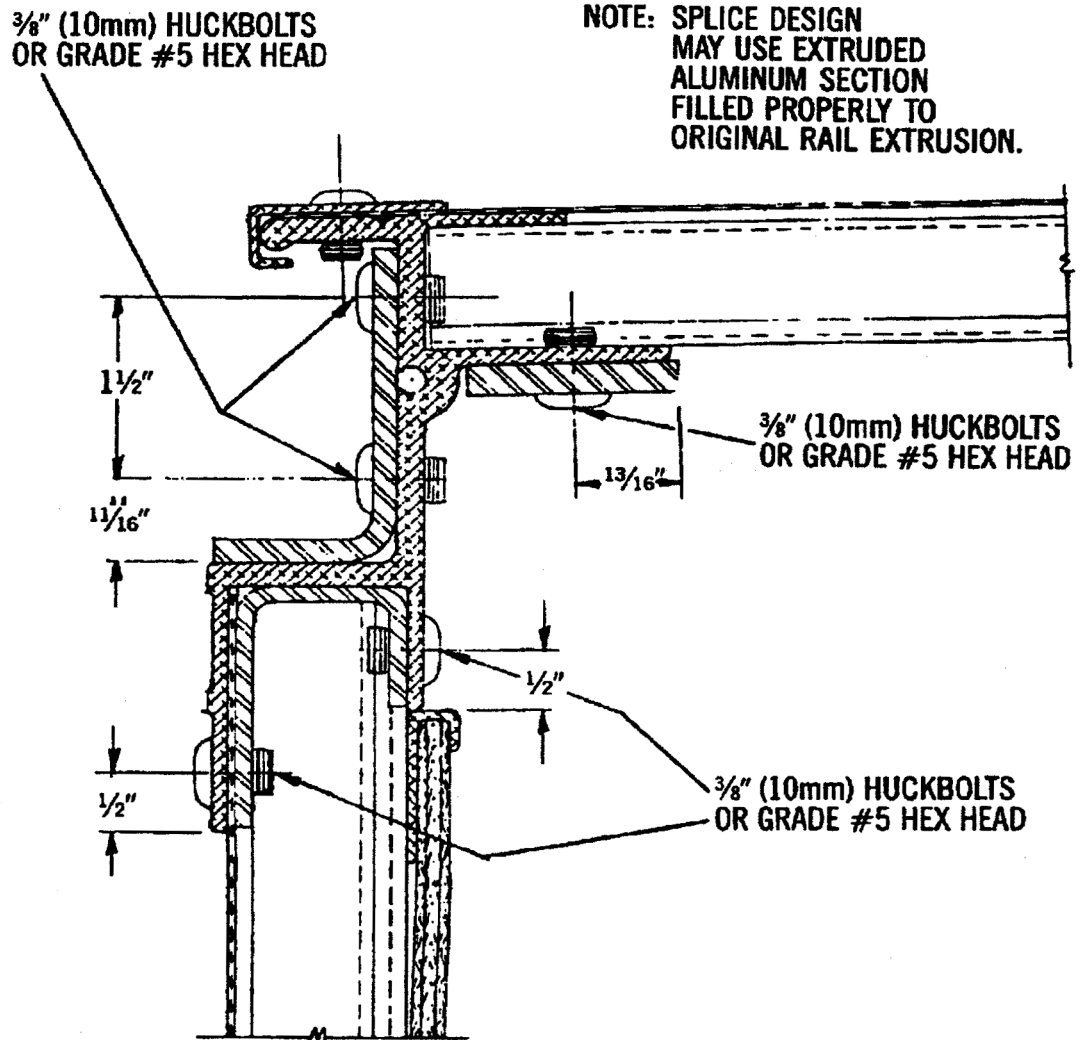

**NOTE:** Splice plate has the option of being installed internally, externally, or both (as above) to top rail.

Figure B-17 Splicing of Bottom Rails

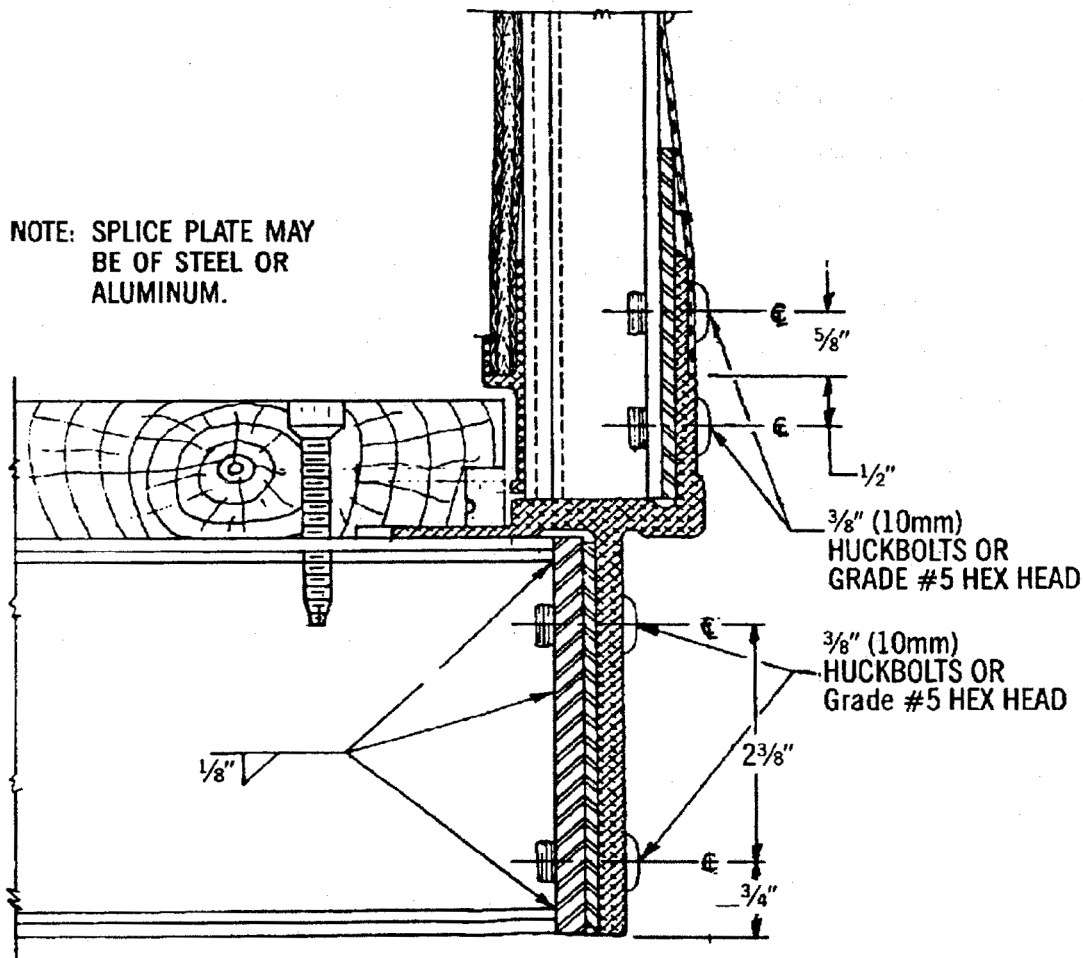

**NOTE:** Bottom rail splice plate must extend a minimum of three crossmembers.

## B10. Riveting

### a. General

A large portion of components on trailers and containers is engineered to be permanently fastened together by riveting. The importance of using correct riveting techniques cannot be overlooked in the discussion of proper trailer or container repairs. Listed below are some riveting techniques (refer to **Figure B-18**, **Figure B-19**, and **Figure B-20**).

### b. Inspection Procedures for Locating Defective or Loose Rivets

There are several methods of detecting a loose or defective rivet.

- (1) If a rivet can be turned or shaken with the fingers, it should be replaced.
- (2) If looseness is suspected but cannot be verified by turning it, a sharp rap with a hammer will produce a dull sound in a loose rivet.

## AAR Intermodal Interchange Rules

- (3) A further check is to coat the rivet head with light oil, wait a few seconds for the oil to penetrate, wipe it clean, and rap it again with a hammer. If oil appears around the edges again, the rivet should be replaced.
- (4) Finally, the appearance of evidence of movement or shifting between riveted parts, such as bare or shiny areas, is a good indication of the need for replacement.

### c. Proper Riveting Procedures

- (1) Select a rivet length so that the shank before riveting protrudes through the material  $1\frac{1}{2}$  times the diameter of the shank (**Figure B-18**).

**Figure B-18 Proper Rivet Length**

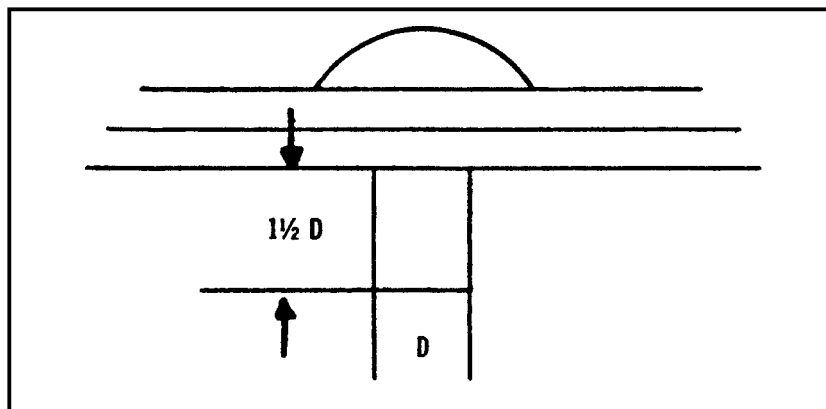

### (2) Tools

The two most important tools for producing a good rivet application are the rivet set and the bucking bar.

#### (a) Rivet Set

It is important to select and use the correct rivet set and size that will match the head of the rivet being used. An oversized set will flatten the rivet head and damage the adjacent material, while an undersized set will damage the rivet head. The rivet set is held in the gun by a retaining spring. Always be sure that the spring is securely in place prior to starting. The strike of the rivet gun is adjustable and should be tested against a block of wood to ensure proper strike.

**NOTE:** Soft rivets are prohibited in trailer repairs, except on roof repairs.

## AAR Intermodal Interchange Rules

### (b) Bucking Bar

- 1) The bucking bar is used to produce the flat head (bucked head) on the opposite end of the rivet from the manufactured head. By using the correct bar properly, a bucked head should be produced that is  $1\frac{1}{2}$  times the diameter of the rivet shank and  $\frac{1}{2}$  the diameter in thickness.
- 2) The weight of the bar being used has an effect on the riveting job. If the bar is too light, it will require more action from the riveting gun and will consequently cause damage to the material. A heavy bucking bar will work faster and will keep the vibration of the gun from being transmitted to the mechanic's hand.
- 3) Following are some of the basic rules for using a bucking bar:
  - a) One surface or side of the bucking bar is polished. This is known as the "face" and must be positioned and held correctly to create a proper bucked head.
  - b) Keep the face of the bar parallel to the material. If the bar is canted, the bucked head will be improperly formed, and the material will be damaged.
  - c) The face of the bucking bar must cover the entire rivet end.
  - d) A firm hold on the bar will result in a smoother and faster job and will prevent "chatter."

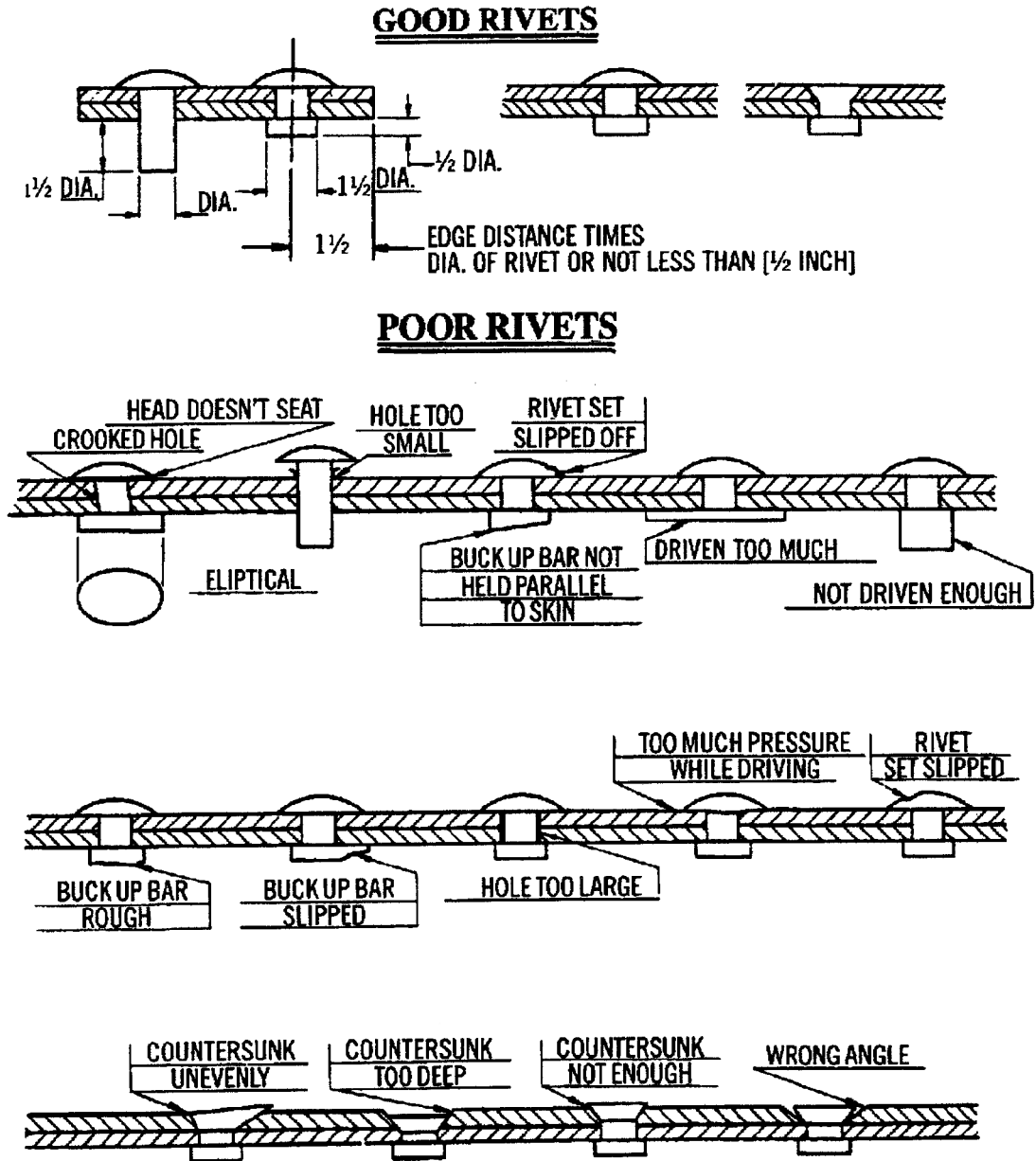

# AAR Intermodal Interchange Rules

### Figure B-19 Good and Bad Rivet Heads



# AAR Intermodal Interchange Rules

## Figure B-20 Solid Rivet Chart — Sizes and Ratings

																				
SOLID ALUMINUM UNIVERSAL HEAD RIVET							SOLID STEEL UNIVERSAL HEAD RIVET													
		SIZE		GRIP RANGE		HOLE PREPARATION					SIZE		GRIP RANGE		HOLE PREPARATION					
	DIA.	LENGTH	MIN.	MAX.	DRILL SIZE	HOLE LIMITS		DIA.	LENGTH	MIN.	MAX.	DRILL SIZE	HOLE LIMITS		DIA.	LENGTH	MIN.	MAX.	DRILL SIZE	HOLE LIMITS
	3/16	3/8	.057	.150	#7	.200/.204		3/16	3/8	.057	.150	#7	.200/.204		3/16	3/8	.057	.150	#7	.200/.204
	3/16	7/16	.119	.212	#7	.200/.204		3/16	7/16	.119	.212	#7	.200/.204		3/16	7/16	.119	.212	#7	.200/.204
	3/16	1/2	.181	.274	#7	.200/.204		3/16	1/2	.181	.274	#7	.200/.204		3/16	1/2	.181	.274	#7	.200/.204
	3/16	9/16	.243	.336	#7	.200/.204		3/16	9/16	.243	.336	#7	.200/.204		3/16	9/16	.243	.336	#7	.200/.204
	3/16	5/8	.305	.398	#7	.200/.204		3/16	5/8	.305	.398	#7	.200/.204		3/16	5/8	.305	.398	#7	.200/.204
	3/16	11/16	.367	.460	#7	.200/.204		3/16	11/16	.367	.460	#7	.200/.204		3/16	11/16	.367	.460	#7	.200/.204
	1/4	1/2	.075	.200	"1"	.270/.277		1/4	1/2	.075	.200	"1"	.270/.277		1/4	1/2	.075	.200	"1"	.270/.277
	1/4	5/8	.199	.324	"1"	.270/.277		1/4	5/8	.199	.324	"1"	.270/.277		1/4	5/8	.199	.324	"1"	.270/.277
	1/4	3/4	.323	.448	"1"	.270/.277		1/4	3/4	.323	.448	"1"	.270/.277		1/4	3/4	.323	.448	"1"	.270/.277
	1/4	7/8	.441	.572	"1"	.270/.277		1/4	7/8	.441	.572	"1"	.270/.277		1/4	7/8	.441	.572	"1"	.270/.277
	1/4	1	.571	.697	"1"	.270/.277		1/4	1	.571	.697	"1"	.270/.277		1/4	1	.571	.697	"1"	.270/.277
	5/16	3/4	.219	.375	"Q"	.328/.336		5/16	3/4	.219	.375	"Q"	.328/.336		5/16	3/4	.219	.375	"Q"	.328/.336
	5/16	13/16	.281	.437	"Q"	.328/.336		5/16	13/16	.281	.437	"Q"	.328/.336		5/16	13/16	.281	.437	"Q"	.328/.336
	5/16	7/8	.343	.500	"Q"	.328/.336		5/16	7/8	.343	.500	"Q"	.328/.336		5/16	7/8	.343	.500	"Q"	.328/.336
	5/16	1	.360	.548	"Q"	.328/.336		5/16	1	.360	.548	"Q"	.328/.336		5/16	1	.360	.548	"Q"	.328/.336
	3/8	5/8	.062	.250	"X"	.395/.404		3/8	5/8	.062	.250	"X"	.395/.404		3/8	5/8	.062	.250	"X"	.395/.404
	3/8	13/16	.173	.361	"X"	.395/.404		3/8	13/16	.173	.361	"X"	.395/.404		3/8	13/16	.173	.361	"X"	.395/.404
	3/8	1	.360	.548	"X"	.395/.404		3/8	1	.360	.548	"X"	.395/.404		3/8	1	.360	.548	"X"	.395/.404
	3/8	1-1/8	.485	.673	"X"	.395/.404		3/8	1-1/8	.485	.673	"X"	.395/.404		3/8	1-1/8	.485	.673	"X"	.395/.404
	3/8	3/4	.111	.300	"X"	.395/.404		3/8	3/4	.111	.300	"X"	.395/.404		3/8	3/4	.111	.300	"X"	.395/.404
	1/4	1-1/4	.812	1.000	"1"	.270/.277		3/8	1-3/16	.547	.735	"X"	.395/.404		3/8	1-3/16	.547	.735	"X"	.395/.404
	1/4	1-7/16	1.062	1.187	"1"	.270/.277		3/16	15/16	.615	.708	#7	.200/.204							

																				
SOLID ALUMINUM COUNTERSUNK RIVET							SOLID STEEL ROUND HEAD RIVET													
		SIZE		GRIP RANGE		HOLE PREPARATION					SIZE		GRIP RANGE		HOLE PREPARATION					
	DIA.	LENGTH	MIN.	MAX.	DRILL SIZE	HOLE LIMITS		DIA.	LENGTH	MIN.	MAX.	DRILL SIZE	HOLE LIMITS		DIA.	LENGTH	MIN.	MAX.	DRILL SIZE	HOLE LIMITS
	1/4	5/8	.200	.325	"F"	.256/.261		3/8	13/16	.173	.361	"X"	.395/.404		3/8	1	.360	.548	"X"	.395/.404
	3/8	7/8	.235	.425	"W"	.386/.391														
	3/8	1-1/4	.610	.600	"W"	.386/.391														
	3/16	7/16	.119	.212	#9	.193/.196														

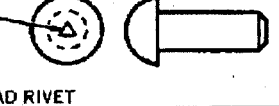
																				
SOLID ALUMINUM BUTTON HEAD RIVET							BRAZIER HEAD RIVET													
		SIZE		GRIP RANGE		HOLE PREPARATION					SIZE		GRIP RANGE		HOLE PREPARATION					
	DIA.	LENGTH	MIN.	MAX.	DRILL SIZE	HOLE LIMITS		DIA.	LENGTH	MIN.	MAX.	DRILL SIZE	HOLE LIMITS		DIA.	LENGTH	MIN.	MAX.	DRILL SIZE	HOLE LIMITS
	3/8	3/8	.111	.300	"X"	.395/.404		3/16	3/8	.031	.187	#10	.192/.196		3/16	3/8	.031	.187	#10	.192/.196
	3/8	13/16	.173	.361	"X"	.395/.404		3/16	7/16	.125	.250	#10	.192/.196		3/16	1/2	.125	.312	#10	.192/.196
	3/8	1	.360	.548	"X"	.395/.404		3/16	9/16	.187	.375	#10	.192/.196		3/16	5/8	.250	.438	#10	.192/.196
								3/16	5/8	.250	.438	#10	.192/.196		3/16	3/4	.312	.563	#10	.192/.196
								1/4	3/8	.031	.125	"F"	.256/.261		1/4	1/2	.062	.250	"F"	.256/.261
								1/4	5/8	.187	.375	"F"	.256/.261		1/4	3/4	.312	.500	"F"	.256/.261
								1/4	7/8	.437	.625	"F"	.256/.261							

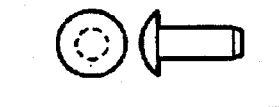

## B11. Axles, Bearings, and Brakes

(See Figure B-21 and Figure B-22)

### a. General

Several components in this manual have been discussed as being integral components of the rail intermodal trailer or chassis; without the proper care and preventive maintenance, bearings and brakes in need of repair delay delivery of freight.

### b. Brakes

#### (1) Brake Inspection

Cracked or broken drums, ruptured diaphragms, other chamber leaks, and missing, broken, or disconnected parts present imminently hazardous conditions likely to result in an accident or breakdown. Trailers or chassis never should be placed in service when any of these conditions exist.

#### (2) Brake Adjustments

- (a) The axle must be raised so that the wheels are free from contact with the ground. Release the brakes; use shop air or tractor air and release the spring brakes, if the system employs spring-loaded parking or emergency brakes.
- (b) While rotating the wheel, tighten the slack adjuster by turning the adjusting screw until the brake lining pressure stops rotation of the wheel. Back off this pressure with the adjusting screw until the brake shoe just releases the drum and allows wheel rotation again.
- (c) An alternate method of adjusting the brakes without raising the wheels from contact with the ground, and probably the most frequently used, is to tighten the slack adjuster until the brake shoe is tight against the drum; then back off carefully until the shoe jerks slightly, indicating it has started to back away from contact with the drum. Strike the drum with a hammer and if drag still exists, the blow will produce a dull thud, indicating further clearance is required.
- (d) When adjustment is completed, check the rod length on both sides for similarity so that application pressure is in balance. The angle made by the push rod and slack adjuster should be approximately 90° when service brakes are applied. Grease and lubricate where necessary to ensure that the linkage is operating without constraint; examine the position of the push rod at chamber exits to determine that it is not bent or rubbing.
- (e) Automatic slack adjuster manufacturers have different procedures in the installation and operation of adjusters. All automatic slack adjusters are designed to automatically maintain a preset stroke or clearance. Self-adjusting brake adjusters should not have to be manually adjusted. Manual adjustments can be made temporarily until an inspection and repair can be completed.

## AAR Intermodal Interchange Rules

### (3) Spring Brake Chambers

- (a) **WARNING:** Spring brake chambers contain high-strength springs that are compressed even at the extended position in the chamber. This spring, if suddenly released, can propel itself or other parts of the brake chamber with enough force to seriously injure personnel.
- (b) Recommendations of the spring brake chamber manufacturer should be followed carefully when inspecting, removing, repairing, servicing, disposing, or otherwise handling spring brake chambers.
- (c) Spring brake chambers that are to be discarded should be safely disarmed before storage. Disarming should be accomplished in a disablement cage or other suitable safety device, using a method recommended by the manufacturer of the spring brake chamber.

### (4) Brake Liners

- (a) Shoes should be coated to prevent corrosion.
- (b) Stainless steel clevis and pins should be used.
- (c) Test to ensure shoe is in proper circumference.
- (d) See **Figure B-22a** for acceptable/unacceptable cracks in shoes.

# AAR Intermodal Interchange Rules

Figure B-21 Axle Assembly

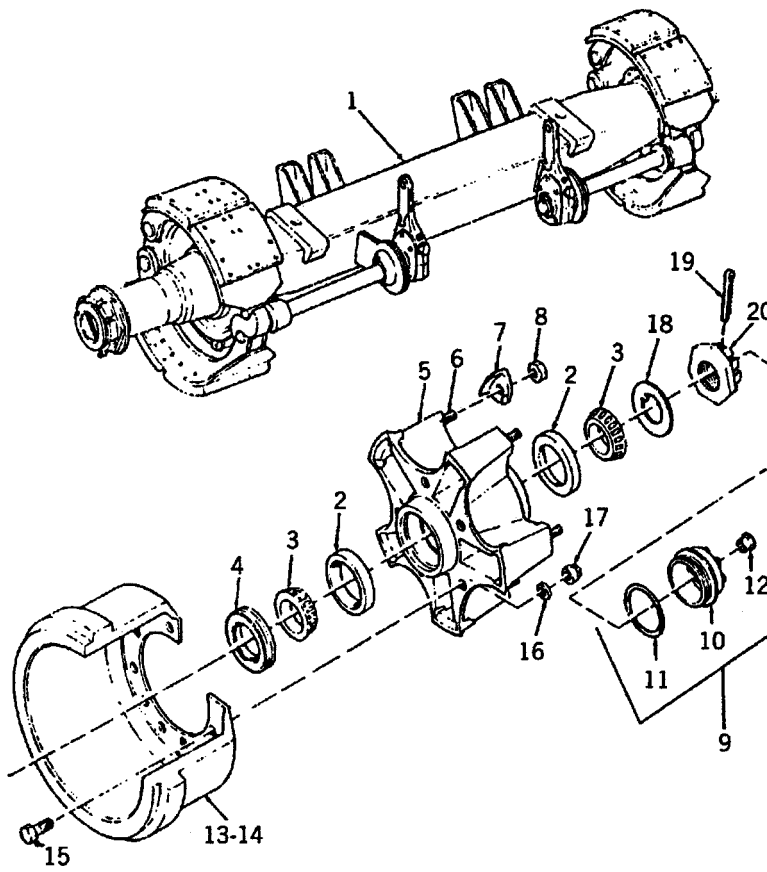

Index No.	Description
1	Axle
2	Cup
3	Cone
4	Seal
5	Wheel
6	Stud
7	Clamp/Wedge
8	Nut
9	Hubcap Kit
10	Hubcap
11	O-Ring
12	Plug
13	Brake Drum
14	Drum Installation Assy
15	Bolt
16	Washer
17	Nut
18	Washer
19	Pin
20	Nut

# AAR Intermodal Interchange Rules

Figure B-22 Axle/Brake Assembly

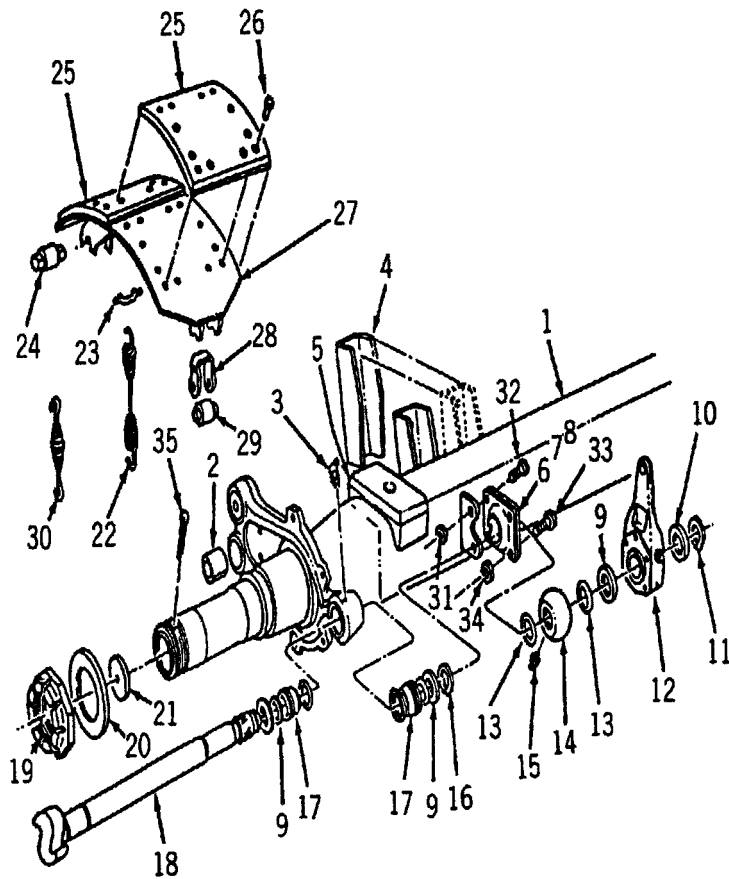

Index No.	Description
1	Tube, Axle
2	Bushing, Anchor Pin
3	Fitting, Lube, Elbow
4	Bracket, Air Chamber
5	Chair, Spring
6	Bracket, Cam Shaft
7	Bracket Retainer, Bolt on Cam
8	Bracket Retainer, Bolt on Cam
9	Washer, Cam Bearing
10	Washer, Shaft End
11	Retainer Ring, External
12	Slack Adjuster Assy
13	O-Ring, Cam Bearing, Inboard
14	Bushing
15	Fitting, Lubrication
16	Retainer Ring, External
17	Bearing Seal Assy
18	Cam Shaft, Left Hand
19	Cam Shaft, Right Hand
20	Washer, Axle
21	Expansion Plug
22	Spring, Return
23	Pin, Return Spring
24	Pin, Brake Anchor Lining & Shoe Assy
25	Lining, Non-Asbestos
26	Rivet, Tubular
27	Shoe Assy, Brake, Unlined
28	Retainer, Roller
29	Roller, Brake Shoe
30	Spring, Anchor Pin
31	Nut, Hex Lock
32	Bolt, Hex Head, 1 1/4" long
33	Bolt, Hex Head, 3/4" long
34	Nut, Hex Lock
35	Pin, Cotter

# AAR Intermodal Interchange Rules

## Figure B-22a Acceptable and Unacceptable Cracks in Shoes

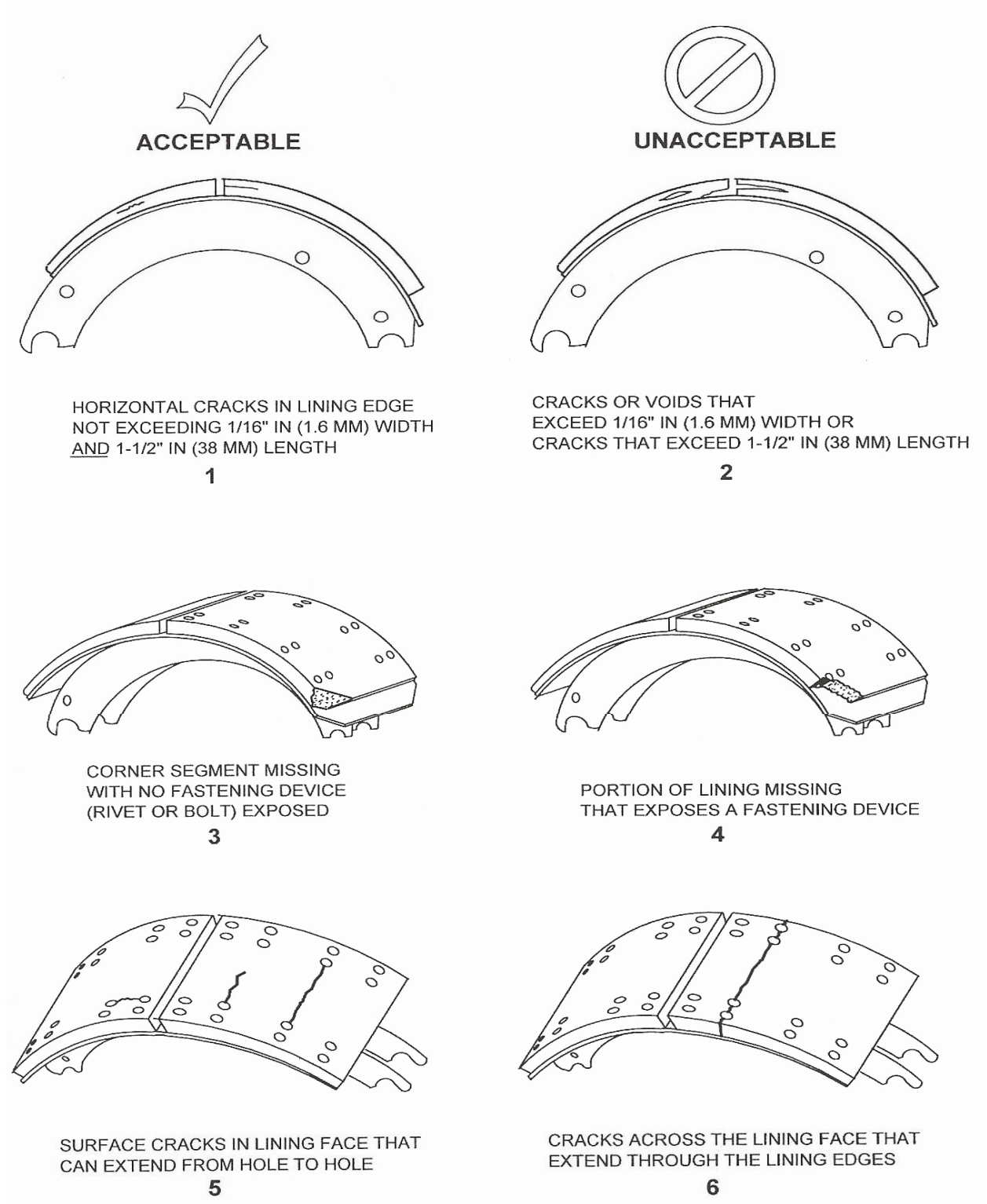

Drawing Courtesy of the Institute of International Container Lessors (IICL)

**B12. Upper Coupler and Kingpin**

(Figure B-23 through Figure B-28)

**a. Kingpin****(1) Repair Restriction**

No repair to the kingpin or any trailer or chassis in intermodal service is allowed without notification to the owner, and then kingpins may be repaired only in accordance with specific instructions from the manufacturer of the trailer or chassis.

**(2) Kingpin Wear Limits**

By permission of the Society of Automotive Engineers, the document *SAE J2228 – King Pin Wear Limits, Commercial Trailers and Semi Trailers*, forms a part of this specification to the extent specified herein. Unless otherwise specified, the current issue of this publication shall apply. All publications are subject to revision, and the users of this document should be certain they are using the current version. Copies of SAE J2228 can be obtained by contacting the Society of Automotive Engineers, 400 Commonwealth Drive, Warrendale, PA 15096.

**(a) Scope**

This provision applies to upper coupler kingpins for commercial trailers and semitrailers conforming to the dimensional requirements of SAE J700 when new and originally installed. The dimensions of SAE J700 are the frame of reference for this document.

**(b) Purpose**

The purpose of this document is to establish maximum parameters for kingpin wear, and to suggest a gauge configuration for inspecting kingpin wear. Kingpins exceeding the conditions of this specification must be removed from service and replaced.

**(c) References**

**Applicable Document**—The following publication forms a part of this specification to the extent specified herein. The latest issue of SAE publications shall apply.

**SAE Publication**—Available from SAE, 400 Commonwealth Drive, Warrendale, PA 15096.

*SAE J700—Upper Coupler Kingpin—Commercial Trailers and Semitrailers*

**(d) Figure B-23** shows minimum diameters and allowable areas for wear on kingpins. Check diameter at several points around the kingpin to detect and measure nonuniform wear conditions. Kingpin wear is restricted to areas shown in **Figure B-23** in crosshatch. Wear on noncrosshatched areas is not acceptable.

## AAR Intermodal Interchange Rules

**Figure B-24** shows areas on the kingpin where nicks, burrs, gouges, etc., are allowed. However, no burr, nick, and/or gouge may exceed 3.2 mm (0.12 in.) in depth. The maximum number of nicks, burrs, gouges, etc., that exceed 1.5 mm (0.06 in.) in length should not exceed 10 on the 50.8 mm (2.00 in.) diameter. Nicks, burrs, gouges, etc., should not exceed 6.4 mm (0.25 in.) in length when measured at their maximum length.

**Figure B-25** and **Figure B-26** show a recommended gauge to inspect:

- 1) Wear on 50.8 mm (2.000 in.) diameter
- 2) Wear on 73.02 mm (2.875 in.) diameter
- 3) Kingpin length
- 4) Kingpin squareness to bolster plate

The gauge shown is of a “No Go” design, so any engagement of the gauge on the appropriate diameter indicates the kingpin is worn and must be removed from service and replaced.

Kingpin length, squareness, and bolster plate flatness must be in accordance with SAE J700. Check squareness at several points around the kingpin to detect an out-of-square condition.

Other gauge configuration and direct reading measurement devices, such as micrometers and dial calipers, also may be used.

### **b. Upper Coupler**

Upper coupler attachment fasteners, when damaged, loose, or missing generally as a result of “scuffing and bottom rails,” should be replaced immediately for safe operation. These fasteners retain the upper coupler in position and play an important role in the overall trailer design. The quantities of these fasteners are based on the amount of shear load and forces introduced by the upper coupler. Any reduction of fasteners, whether damaged, loose, or missing, places the trailer at risk for continuous safe operation.

Figure B-23 Kingpin Wear Limits

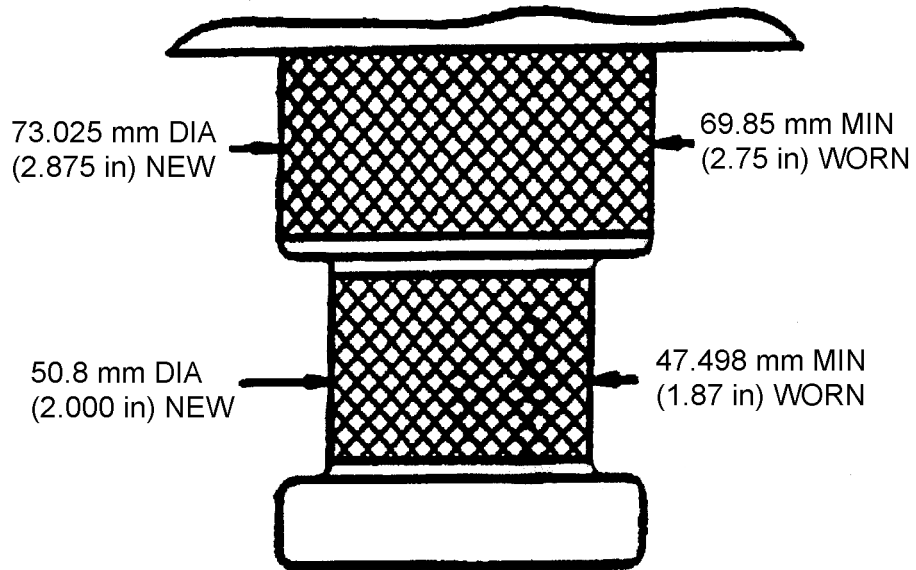
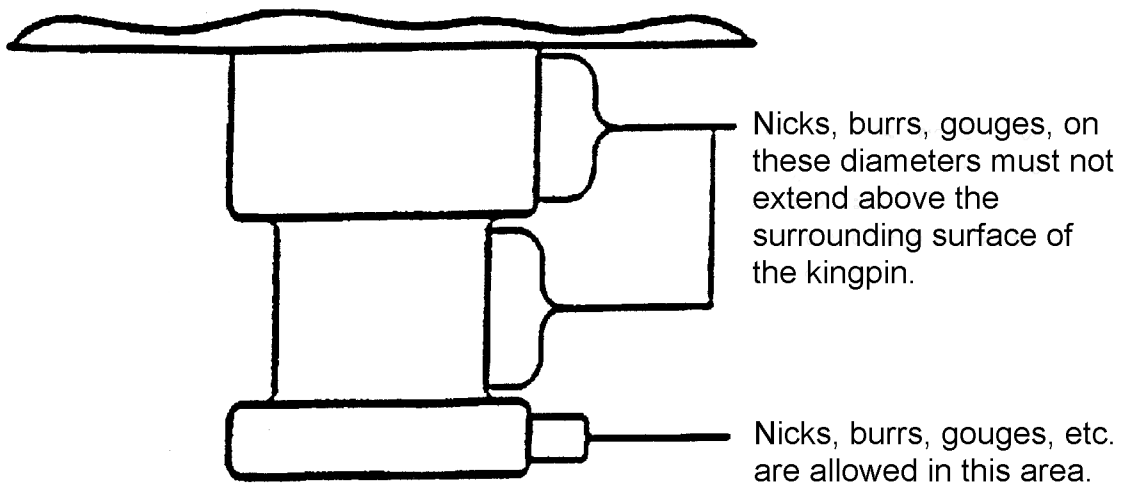

Figure B-24 Kingpin Nicks, Burrs, Gouges





# AAR Intermodal Interchange Rules

**Figure B-25 Inspection of Kingpin Diameters Using One Type of Gauge**

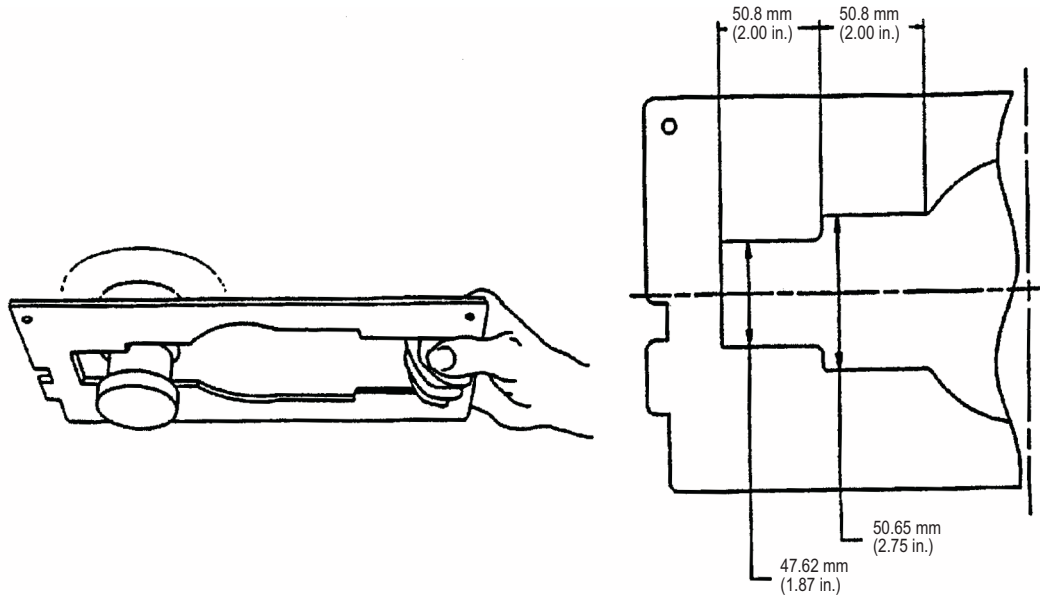

# AAR Intermodal Interchange Rules

**Figure B-26 Kingpin Length and Squareness Check Using One Type of Gauge**

A = 1.250 min / 1.328 max (31.750 mm / 33.731 mm)  
 B = 2.704 min / 2.782 max (66.682 mm / 70.663 mm)  
 C = 3.256 min / 3.354 max (82.702 mm / 85.192 mm)

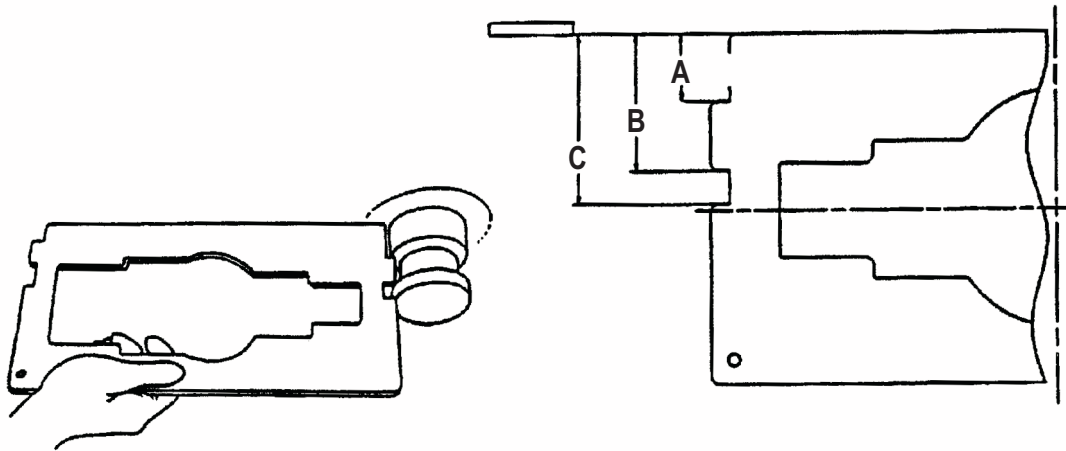

**Figure B-27 Front Frame**

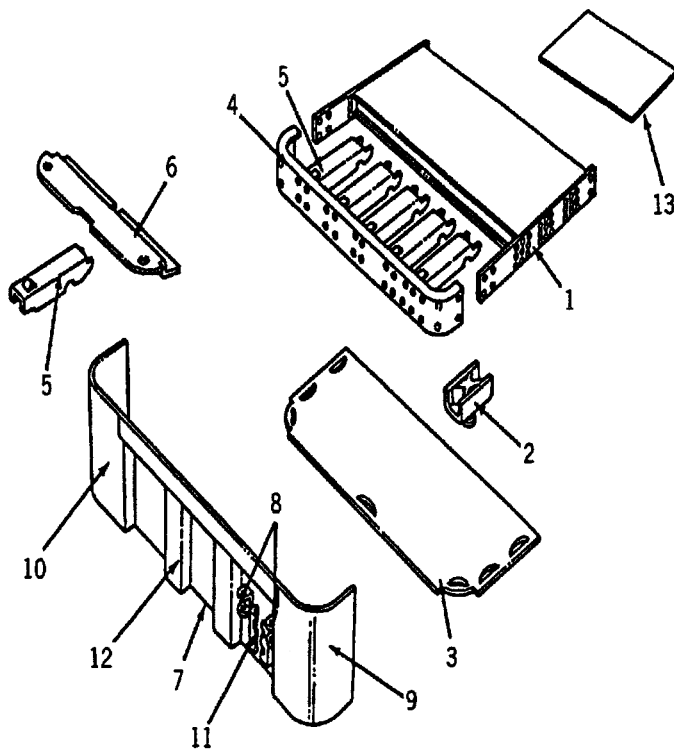

Index No.	Description
1	Coupler Assembly, Upper
2	Kingpin
3	Apron Plate
4	Crossmember, Front
5	Channel, Front Frame
6	Plate, Floor Front
7	Bulkhead Assembly
8	Bracket
9	Corner, Front, Bulkhead, Roadside
10	Corner, Front, Bulkhead, Curbside
11	Angle, Connection Box Support
12	Channel, Front
13	Anti-Hook Plate

# AAR Intermodal Interchange Rules

## Figure B-28 Floorbed and Frame Assembly

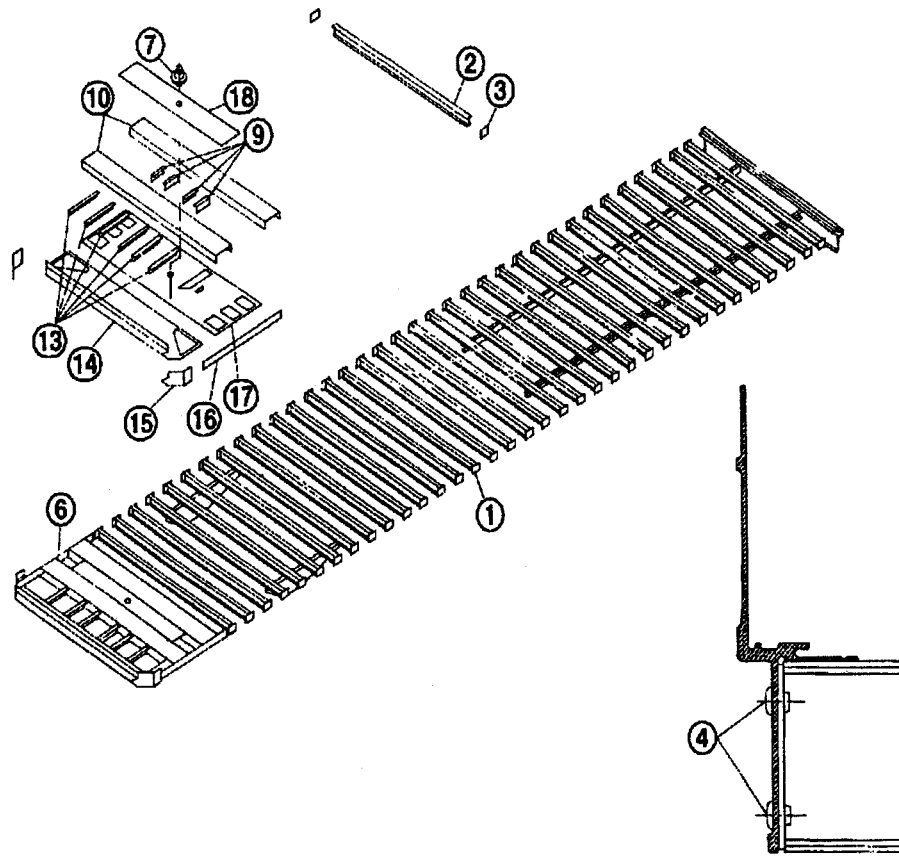

Index No.	Description
1	Sill Assembly
2	Sill
3	Clip, Floor Sill
4	Rivet, Solid Aluminum, Universal Head
6	Fifth Wheel Assembly, Radius Front, 36 in.
7	Kingpin
9	Stiffener

Index No.	Description
10	Crossmember
13	Stiffener
14	Plate, Pickup
15	Corner Radius, Curbside Corner Radius, Roadside
16	Plate, Side
17	Plate, Bottom
18	Plate, Top

## B13. Subassembly

(Figure B-29 and Figure B-30)

### a. Locking Mechanisms

#### (1) Types

Siding undercarriages fall into one of three categories with regard to the manner in which they are locked into place beneath the trailer or chassis:

- (a) Retractable pins operated by a pull handle or level on the slider
- (b) Removable stop bars, one located in front, and one located in back of the slider
- (c) A combination of retractable pins and a removable bar

#### (2) Safety Requirement

Regardless of the type of locking mechanism used, retractable pins and removable bars are the principal structural elements holding the slider in place beneath the trailer or chassis. If these are not maintained in proper working order, or if they are not utilized in the manner prescribed by the manufacturer, the slider can become detached from the trailer or chassis, and a serious accident can result.

### b. Guide and Hold-Down Brackets

All guide and hold-down brackets must be in place and in good repair for safe operation. These brackets provide all or part of the lateral and vertical retention of the slider, and their maintenance is required for safe operation of the trailer or chassis.

### c. Maintenance

- (1) Perform scheduled maintenance of the suspension and slider per the manufacturer's recommendation.
- (2) Perform repeat examination of all components, especially the removable stop bar and/or locking pin mechanisms, on a regular basis during preventive maintenance or safety inspections.
- (3) Replace worn or broken components with factory-approved replacement parts.

---

**WARNING:** Failure to check for proper locking pin engagement prior to driving away and failure to take proper preventive maintenance measures can lead to slider malfunction and possible accident, resulting in property damage, personal injury, or even death.

---

## AAR Intermodal Interchange Rules

### **d. Air Rides**

Air-ride suspension reduces tire wear, road wear, fuel consumption, and vibration.

System components must be maintained to prevent them from becoming damaged, worn, or misaligned. Any abnormalities such as loose or missing fasteners, bushing connections, or abnormal tire wear should be assigned for maintenance.

Anytime parts are replaced for service, damage, wear, or failure, complete suspension should be checked.

# AAR Intermodal Interchange Rules

**Figure B-29 Subframe Assembly, Lower—FS Slider**

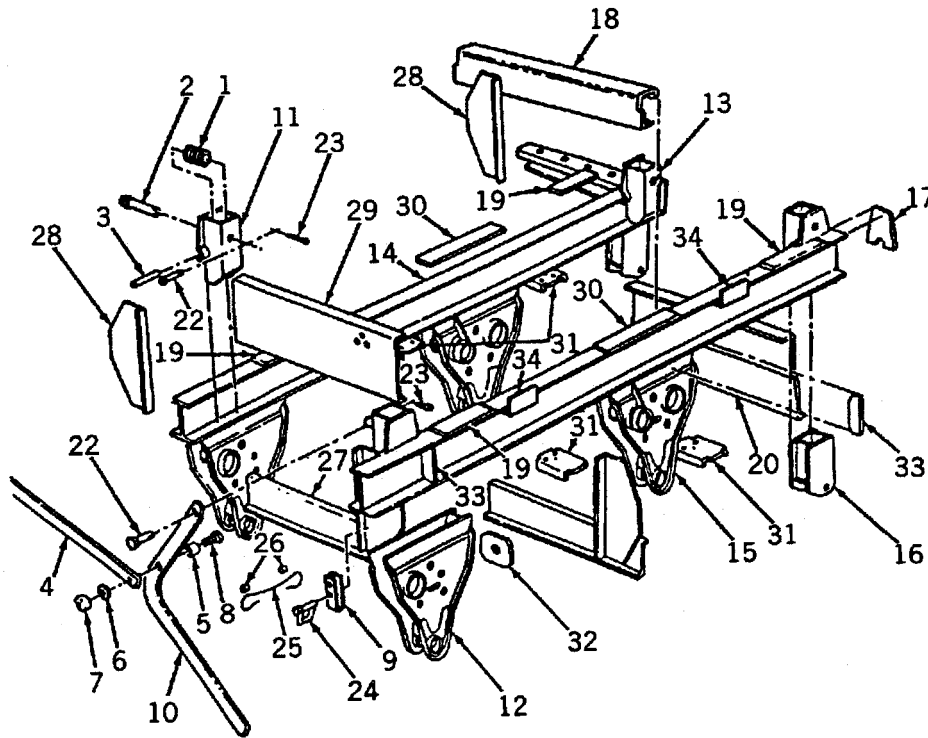

Index No.	Description	Index No.	Description
1	Spring, Lock Pin	18	Crossmember
2	Pin, Lock	19	Slider Plate
3	Pin	20	Crossmember
4	Crossbar	22	Lock Pin, Select-A-Point
5	Sleeve	23	Cotter Pin
6	Washer, Plain	24	Lock Pin
7	Nut, Hex	25	Cable, Flexible
8	Bolt, Hex Head	26	Sleeve
9	Guide, Locking Lever	27	Crossmember
10	Lever	28	Gusset
11	Bracket Assy, Front	29	Crossmember
12	Hanger Assy, Front	30	Plate, Slider
13	Bracket Assy, Rear	31	Bracket, Air Tank Mounting
14	Rail, Lower Subframe	32	Gusset, Hanger
15	Hanger Assy, Equalizer	33	Gusset, Hanger
16	Hanger Assy, Rear	34	Rail Guide
17	End Plate		

# AAR Intermodal Interchange Rules

## Figure B-30 Spring Assembly

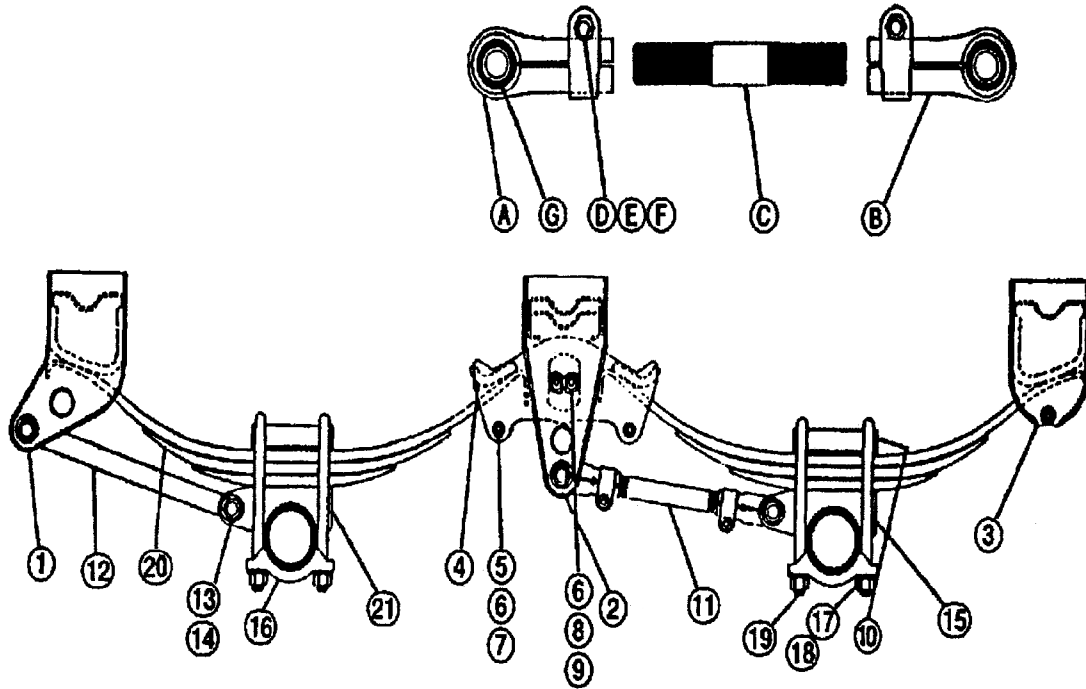

Index No.	Description	Index No.	Description
1	Hanger, Front Spring	15	Spring Seat (Round or Square)
2	Hanger, Equalizer	16	Bottom Plate (Round or Square)
2-4	Hanger & Equalizer Straddle Mount Assembly	17	Flat Washer
3	Hanger, Rear Spring	18	Hex Bolt
4	Equalizer w/Rubber Bushing	19	U-Bolt (Round or Square)
5	Sleeve Spacer	20	Spring Assembly (Single/Multiple Leaf)
6	Hex Nut	21	Spring Seat (Round or Square)
7	Hex Bolt	A	Eye End, Adj. Torque Arm L.H.
8	Step Bolt	B	Eye End, Adj. Torque Arm R.H.
9	Double Washer with Lock Tab	C	Screw, Adj. Torque Arm
10	Top Plate (for round/square U-bolt)	D	Hex Nut
11	Torque Arm, Adjustable	E	Flat Washer
12	Torque Arm, Non-Adjustable	F	Hex Head Bolt
13	Torque Arm Bolt	G	Bushing
14	Flange Locknut		

## B14. Electrical and Air Systems

### a. Electrical System

#### (1) Lighting System

- (a) Lighting systems shall be 12-volt design with conventional seven-conductor electrical connector socket wires and be installed per **Figure 1**.
- (b) The lighting system on trailers consists of a light connection located on the nose of the trailer, four red marker lights, two amber marker lights, four amber reflectors, two red reflectors, two combination stop and tail lights, one R.H. directional signal, one L.H. directional signal, one license plate light, auxiliary lights, and all the necessary wiring, wiring clips, terminals, and connectors for the correct functioning of the system to meet required Federal Motor Vehicle Safety Standard 108. Lights are recessed for protection from trailer sides and ends, with no opening permitted that will allow water into the system.
- (c) Chassis lights consist of two combination stop and tail lights, one R.H. directional signal, one L.H. directional signal, and one license plate light. Lights are recessed for protection with no opening permitted that will allow water into the system.

#### (2) Protective Coating

It is recommended that dielectric grease be used as a protective coating on all electrical connectors to ensure longevity and performance of the electrical connection.

#### (3) Welding

Welding on trailers and chassis can be hazardous to sensitive electrical components such as lights. Before welding, check the following:

- (a) All air lines are protected from heat and splatter.
- (b) All anti-skid components are shielded and protected from heat and splatter.
- (c) A ground clamp is placed as close to the weld as practical.
- (d) Electrical trailer power cord must be disconnected from power unit.



# AAR Intermodal Interchange Rules

## b. Air System

### (Figure B-31 and Figure B-32)

Air brake lines are designed to be accessible from the exterior of the trailer, normally running in the center of the trailer, accessible from beneath. Caution should be taken when working on the floor, crossmembers, etc., so as not to damage the integrity of the system.

---

**WARNING:** Air chamber diaphragm replacement is *not* recommended.

---

#### (1) Air Relay Valve Replacement

If relay valves require replacement as a result of corrosion or mechanical damage on trailers or chassis, replacement should be on a one-for-one basis with the OEM replacement. Do not install a relay valve that has a different manufacturer than the valve originally installed. Refer to the manufacturer for information on replacement valves.

#### (2) Drain Cock Manual Replacement

All air tanks have at the lower-most point a threaded boss and a manual rotating type valve, which allows bleeding air pressure and entrapped moisture, dirt, and debris from the tank. These valves, due to their constant exposure to moisture, do malfunction and are replaced with a similar type rotating valve by merely unthreading the defective valve and inserting a replacement component.

#### (3) Glad Hand Placement

Glad hands shall be mounted in the recessed portion of the nose of the trailer or chassis so as to make the glad hands flush or recessed, to prevent damage from impact to the nose of the trailer or chassis.

# AAR Intermodal Interchange Rules

### Figure B-31 Air Connections

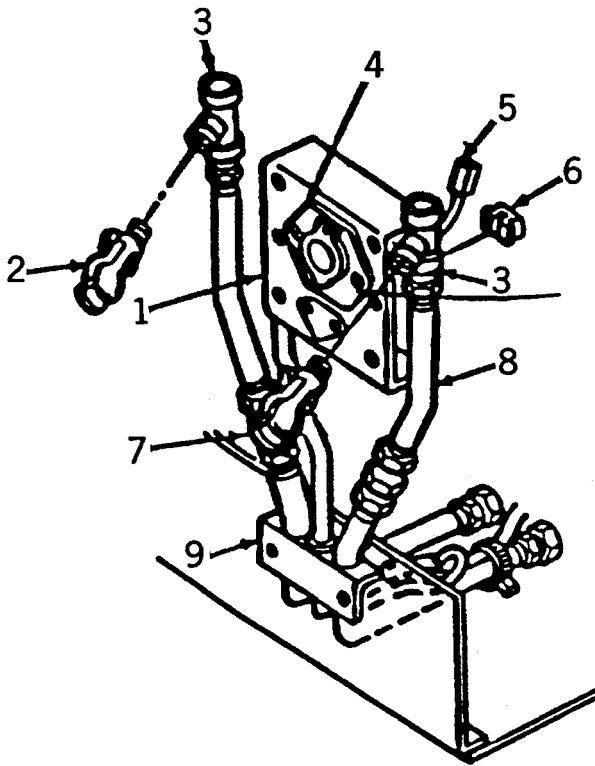

Index No.	Description
1	Box, Light Receptacle
2	Coupling, Air, Service Glad Hand
3	Fitting, 45 Deg. Y-Bend
4	Receptacle, 7-Way
5	Pig Tail
6	Nut, Retainer Speed Clip
7	Coupling, Air, Emergency Glad Hand
8	Hose Assembly
9	Coupling Assembly, Airline

# AAR Intermodal Interchange Rules

**Figure B-32 Air Actuation Brake System**

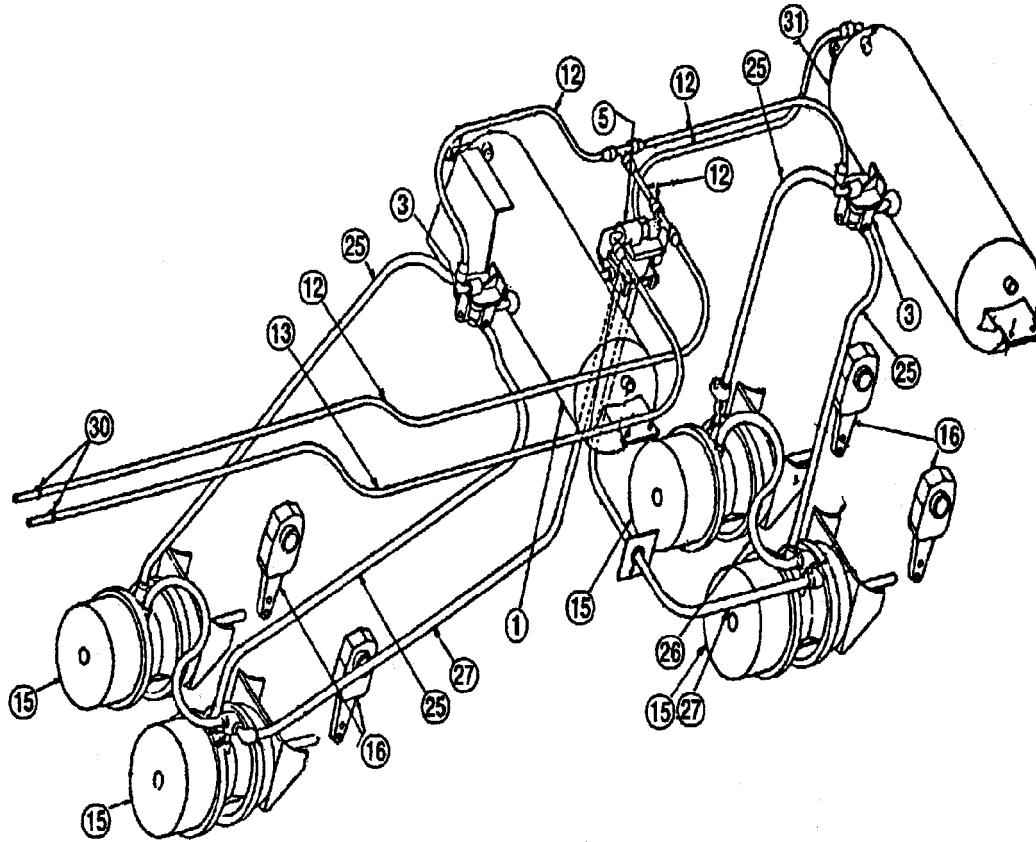

Index No.	Description
1	Service Reservoir
3	Valve
5	Valve
12	Tubing
13	Tubing
15	Spring Brake Chamber
16	Slack Adjuster
25, 26, 27	Hose Assembly
30	Conduit
31	Service Reservoir

## AAR Intermodal Interchange Rules

### B15. Tires

#### a. Safety Precautions

When working with tires, several safety precautions should be followed. Listed below are items to be considered:

- (1) Do not reinflate a tire that has been run while flat without first inspecting the tire, rim, and wheel assembly. A tire that is 20% under-inflated is considered flat. Tire should be inspected for defects. Double-check the lock ring for damage; make sure it is secure in the gutter before inflation.
- (2) Always exhaust all air from both tires of a dual assembly prior to removing any rim components or any wheel components, such as nuts and rim clamps. Make sure you remove the valve core and exhaust all air from the tires.
- (3) Always stand to one side when you apply air pressure to the tire.
- (4) Check rim components periodically for fatigue cracks. Replace all cracked, badly worn, damaged, severely rusted, or welded components. Three-piece rims are prohibited.
- (5) Make sure that the correct parts of a tire/rim assembly are being assembled. Mixing parts of one manufacturer's rims with those of another is prohibited.
- (6) Double-check to make sure all components are properly seated prior to inflating a tire.
- (7) Do not overload rims or overinflate tires. (Check with the rim manufacturer if special operating conditions are required.)
- (8) Do not seat rings by hammering while the tire is inflated. Do not hammer on an inflated or partially inflated tire/rim assembly.
- (9) Do not inflate any tire before all side and lock rings are in place. Check components for proper assembly again after inflating to approximately 5 psi.
- (10) Never sit on or stand in front of a tire and rim assembly that is being inflated. Use a clip-on chuck, and make sure the air hose is long enough to permit the person inflating the tire to stand to the side of the tire (minimum 24 in.).
- (11) All studs and lug nuts should be replaced according to DOT regulations.

---

**CAUTION: Always inflate tires that have been removed from trailers and chassis in a safety cage. Tires may be inflated and deflated while on the trailer or chassis.**

---

# AAR Intermodal Interchange Rules

## b. Inflation

Tires should be properly inflated according to the individual tire's standards.

- (1) Underinflation of tires causes abnormal wear at the sides of the tread because the outer edges of the tire carry the load while the center tends to flex up away from the road. This causes the tire to run hotter.
- (2) Overinflation of tires causes abnormal wear in the center of the tread, also shortening the life of the tire because the center of the tire tread carries more than its share of the load.

## c. Vacant

## d. Vacant

### B16. DOT Underride Guard

DOT underride guards are assemblies required by DOT specifications that are fastened to rear sill assemblies and/or slider rails and designed to reduce damage in rear-end collisions (refer to FMVSS 223 and FMVSS 224).

- a. A vertical bend in excess of 3 in. in the horizontal member should be repaired.
- b. If the end of the horizontal member is bent upward, it can be bent down to its original position. If it is bent downward, it can be left alone or bent up to its original position. If it is bent forward less than 3 in., no repair is needed.
- c. If the middle of the horizontal member is bent forward, or if the entire guard is bent forward, consult the manufacturer for repair guidelines.
- d. Use only cold bending methods. Repetitive bending should be avoided.
- e. With guard damage, the rear crossmembers, rear sill, vertical members, and the last 6 feet of the floor also must be inspected for damage.
- f. Missing guards should be replaced with an OEM assembly or an assembly fabricated to the same specifications.

# AAR Intermodal Interchange Rules

THIS PAGE LEFT BLANK INTENTIONALLY

## APPENDIX C

### GLOSSARY

The following terms when used in this Standard shall have the meaning set forth.

#### C1. General Terms

---

**RECORDED IMAGE**—A high-resolution photograph or video.

#### C2. Trailer Component Glossary (page 1 of 4)

(Refer to **Figure C-1** and **Figure C-2**)

---

**AIR BRAKE SYSTEM**—A brake system that uses compressed air as the means of transmitting pressure or force from driver control to service brakes.

**ANTILOCK SYSTEM**—That part of a service brake system that automatically controls the degree of rotational wheel slip at one or more wheels during braking.

**AXLE**—A beam with spindles about which wheels rotate.

**AXLE SPINDLE**—The machined steel rod or shaft (usually heat-treated and hardened) at each end of the axle that is contoured to accept wheel bearings, and around which the wheels rotate.

**BRAKE CHAMBER**—Converts differential air pressures into mechanical forces that are applied to wheel brakes through mechanical linkage. (Also called “air chamber,” “vacuum chamber,” “cans,” “boosters,” “air brake chamber,” “vacuum-brake chamber,” “vacuum boosters.”)

**BRAKE SPIDER**—The center plate, either bolted or welded to the axle, to which the brake assembly is attached.

**BULKHEAD**—A structure used to protect against damage caused by shifting cargo and/or to separate loads.

**BUMPER**—A structure designed to provide rear-end protection. Also called DOT underride guard.

**CARGO CONTROL TRACK**—A vertical or horizontal structural member, normally attached to sidewall posts or flooring, with pierced slots for use with cargo tie-off straps or double-decking components or other restraining devices.

**CERTIFICATE HOLDER**—A moisture-proof container provided for storage and easy access to trailer-related literature such as licenses, registration, defect and maintenance information. (Also called “Registration Holder” and “Defect Card Holder.”)

**CERTIFICATION LABEL (NATIONAL HIGHWAY TRAFFIC SAFETY ADMINISTRATION)**—A label permanently affixed to forward left side of the trailer stating that the vehicle conforms to all applicable Federal Motor Safety Standards in effect on the date of original manufacture.

**CLEARANCE LAMPS**—Lamps mounted on the floor, rear, and sides of a vehicle that indicate its overall length and width.

# AAR Intermodal Interchange Rules

## C2. Trailer Component Glossary (page 2 of 4)

(Refer to **Figure C-1** and **Figure C-2**)

**CONNECTION BOX**—Contain fittings for trailer emergency and service brake connections and electrical connector to which the lines from the towing vehicle may be connected. (Also called “junction box,” “light box.”)

**CONVERTER DOLLY**—A component with a fifth wheel lower half or equivalent mechanism; the attachment that allows other units to be added.

**CROSSMEMBER**—A structural member attached to the bottom side rails that support the floor. (Also called “bolster,” “sill,” “beam.”)

**CUBIC CAPACITY**—Useful internal load-carrying space usually expressed in cubic feet, cubic yards, or U.S. gallons. (Also referred to as “available cube.”)

**CURBSIDE (RIGHT SIDE)**—**[ROADSIDE (LEFT SIDE)]** Viewing the trailer from the rear, the curbside is right and roadside is left. The terms to be used on repair orders are right and left side.

**DOLLY WHEELS**—A set of steel wheels that serve as ground contact for support of the trailer. (Also see Sand Shoe)

**DOOR HEADER**—Horizontal (structural) framing member over a door opening. (Also known as the “rear header.”)

**DOOR HINGE**—A device that secures the door to the trailer frame, allowing the door to turn or move.

**DOOR HOLD BACK**—The device used to hold doors in the open position. Normally made two-piece, male and female, with one part attached to the door and the other to the side of the trailer. (Also referred to as “tie-backs.”)

**DOOR SILL**—Horizontal frame member at bottom of a door opening.

**ELECTRICAL CONNECTOR (7-WAY ELECTRICAL CONNECTOR SOCKET)**—A receptacle designed to accept truck tractor electrical cable plugs.

**FIFTH WHEEL**—A device mounted on a truck tractor or a converter dolly that mates with and pivots within the lower coupler of a truck tractor or converter dolly while coupling the two units together.

**GLAD HANDS**—Fittings for connection of air brake lines between vehicles. Vacuum brake hose connectors are also called “hose couplings.”

**GROMMET**—A device that serves as a support and protection to that which passes through it.

**GROSS AXLE WEIGHT RATING (GAWR)**—The rated capacity at the tire-ground interface; reflects the “weakest link” in the entire suspension system, whether it be the springs, axles, wheels, rims, or tires.

**GROSS VEHICLE WEIGHT RATING (GVWR)**—The GVWR for semitrailers is the sum of the trailer tare weight and that uniformly distributed payload that will result in a suspension load at the tire-ground interface equal to the sum of the trailer’s gross axle weight ratings (GAWR), with a limitation imposed by practical or structural considerations.

**GROSS WEIGHT**—The weight of a trailer together with the weight of its entire contents.



## AAR Intermodal Interchange Rules

### C2. Trailer Component Glossary (page 3 of 4)

(Refer to **Figure C-1** and **Figure C-2**)

---

**IDENTIFICATION LAMPS**—Lamps used to identify front, rear, and side of trailers, as specified by the Federal Motor Vehicle Standard 108.

**INTERIOR LINING (PLYWOOD LINERS/PLY-LINERS)**—Materials used in the interior of trailers to protect side panels, roof bows, and posts.

**KINGPIN**—Attaching pin on a semitrailer that mates with the pivots within the lower coupler of a truck tractor or converter dolly while coupling the two units together.

**LIFT PADS**—Protective hardware affixed to lower side rails of a TOFC trailer to distribute stresses during trailer lifting and handling operations.

**MANIFEST BOX**—A moisture-proof container used for storage of important documents; usually located on the nose of the trailer.

**PANEL**—A section of material used to cover the exterior of a trailer.

**PICK-UP PLATE**—A plate structure located forward of the kingpin and terminating at the approximate front of the vehicle; designed for initial contact with the fifth wheel during coupling.

**POST**—Vertical structural member to which panels and sometimes doors are attached.

**REAR CROSSMEMBER (SILL)**—The horizontal member at the extreme rear of the trailer normally used to mount rear bumpers and stop, turn, and tail lights.

**REAR DOORS**—Hinged structures provided at the rear of the trailer to allow access to the cargo area when opened.

**REFLECTOR**—Material permanently fixed on a vehicle to reflect the light from all sources, but primarily from the head lamps of an approaching motor vehicle.

**RIM**—A metal support for a tire or a tire and tube assembly, upon which the tire beads are seated.

**ROADSIDE (LEFT SIDE)**—see Curbside (Right Side)

**ROOF BOW**—An interior structural member attached to both top side rails.

**RUB RAIL**—A rail extending horizontally along the exterior of a trailer sidewall, or along the longitudinal edge of a platform trailer, intended as crush protection for less rigid components of trailers frequently operated in close quarters.

**RUNNING LIGHTS**—Marker, clearance, and identification lights; required by regulations.

**SAND SHOE**—A flat steel plate that serves as ground contact for support of the trailer. (Also see Dolly Wheels)

**SCUFF LINER**—A strip installed along the lower inside of a trailer to protect the lining, side panels, or posts from wear or damage.

**SIDE RAILS, LOWER**—The main longitudinal frame member located at the lower edge of the trailer to connect the side wall and floor structures.

## C2. Trailer Component Glossary (page 4 of 4)

(Refer to **Figure C-1** and **Figure C-2**)

---

**SIDE RAILS, UPPER**—The main longitudinal frame member used to connect the roof and the side wall structures.

**SLACK ADJUSTER**—Adjustable mechanical lever used to transmit brake chamber force to the brake camshaft when brakes are applied. Slack adjusters are designed to compensate for brake lining wear.

**SLIDING UNDERCARRIAGE**—An undercarriage with a subframe that allows fore-and-aft adjustment of its location on the trailer; used to shift a greater part of the gross load onto the kingpin or the suspension. (Sometimes referred to as a “slider.”)

**SUPPORTS**—Devices generally adjustable in height, used to support the front end of a semitrailer in an approximately level position when disconnected from a towing vehicle. (Also referred to as “landing gears,” “props,” “dollies,” “legs.”)

**TANDEM AXLE**—A two-axle assembly with an equalizing means for transferring weight between axles.

**TOFC**—Abbreviation for “trailer-on-flatcar.” (Also referred to as “piggyback.”)

**TOFC PLATE**—A plate structure extending approximately 24 in. rearward of the upper coupler plate that offers protection during coupling and uncoupling to the flatcar stanchion. (Also referred to as “G-85 plate,” “flatcar extension plate,” “kick plate.”)

**UNDERCARRIAGE**—Complete sub-frame, suspension with one or more axles that may be interconnected, and wheels, tires and brakes. (Also referred to as “bogie” or “running gear.”)

**UPPER COUPLER ASSEMBLY**—Upper coupler plate, reinforcement framing, and fifth-wheel kingpin mounted on a semitrailer. (Also referred to as “upper fifth wheel assembly.”)

**UPPER COUPLER PLATE**—A plate structure through which the kingpin neck and collar extend. The bottom surface of the plate contacts the fifth wheel when the trailer is coupled. (Also referred to as “fifth wheel plate.”)

## C3. Container Component Glossary (page 1 of 2)

---

**COFC**—Abbreviation for container-on-flatcar.

**COLLAPSIBLE FREIGHT CONTAINER**—Freight container of rigid construction, the major components of which can easily be folded or disassembled and then reassembled. (Also referred as “flat rack.”)

**CONTAINER**—A unit of transport equipment that is

- a. of a permanent character and strong enough for repeated use.
- b. specially designed to facilitate the carrier of goods by one or more modes of transport without intermediate reloading.
- c. fitted with devices permitting its ready handling, particularly its transfer from one mode to another.

The term “container” does not include vehicles or conventional packing. (Also referred to as “freight container,” “cargo container,” “intermodal container.”)

**CONTAINER CHASSIS**—A frame equipped with wheels, landing gear, and kingpin assembly, excluding floor, sides, and roof, and with locking devices for securing and transporting a container as a wheeled vehicle.

**CONTAINER DISPLACEMENT**—The outside cubic volume of the container.

**CORNER FITTINGS**—Fittings located at the eight corners of the container that provide means for handling, stacking, and securing the container. (May also be called “corner castings.”)

**CORNER STRUCTURES/POST**—Vertical frame components located at the four corners of the container, integral with the corner fittings, and connecting the roof, floor, and wall structures of closed containers, or the wall and floor structures of an open top container.

**CROSSMEMBERS**—Structural members attached to the bottom side rails that support the floor. (Also called “bolster,” “sill,” or “beam.”)

**CUBIC CAPACITY**—Useful internal load-carrying space, usually expressed in cubic feet, cubic yards, or U.S. gallons. (Also referred to as “available cube.”)

**DOOR HEADER**—Horizontal (structural) framing member over a door opening. (Also known as the “rear header.”)

**DOOR SILL**—Horizontal frame member at bottom of a door opening.

**END DOOR**—Weather-tight movable swinging structure to provide access to the cargo space.

**END WALL**—Assembly surrounded by the end frame and wall at either end of the container.

**FLOOR**—The cargo-carrying surface of the container. (Also referred to as “deck.”)

**FORK POCKETS**—The structural openings or sleeves in the base of the container that permit entry of fork lift devices.

**GROSS WEIGHT**—The allowable total weight of the container and cargo, exclusive of the chassis.

## AAR Intermodal Interchange Rules

### C3. Container Component Glossary (page 2 of 2)

---

**INTERFACE SUPPORTS (KNEE BRACE)**—Structural reinforcements of a prescribed square area within a designated location on the underside of the container. It is designed to provide intermediate support points when the loaded container is being transported on a chassis.

**TARE WEIGHT**—Weight of the empty freight container, including its normal complement of lading restraint devices.

**TWIST LOCK**—A mechanically operated device located on the corners of a container chassis and on automatic lifting spreaders, used for securing a container during transport or transfer.

## C4. Tire Glossary (page 1 of 4)

(Refer to **Figure C-3** and **Figure C-4**.)

**BASE WIDTH**—That portion of the tread rubber that joins to the buffed surface of the worn tire.

**BEADS**—the anchoring part of the tire that is shaped to fit the rim. Made of high-tensile steel wires wrapped and reinforced by the plies.

**BEAD SEALING AREA**—The flat area and heel area of the bead that contacts the rim. With tubeless tires, the bead area seals to the rim flange to retain air.

**BELTED BIAS TIRES**—Tires constructed so the ply cords extending from bead to bead lie at alternate angles substantially less than 90° to the centerline of the tread. On top of the body plies are two or more belt plies extending approximately from shoulder to shoulder, running circumferentially around the tire at alternate angles.

**BIAS PLY TIRES**—Tires constructed so the ply cords extend from bead to bead and are laid at alternate angles substantially less than 90° to the centerline of the tread.

**BODY PLYS**—Layers of rubber-coated parallel cords extending from bead to bead.

**BREAKS (CRACKS)**—A surface opening extending into or through the plies.

**Flex Breaks**—A break into or through one or more plies, usually parallel to the beads.

**Impact Breaks**—A star or X-shaped or diagonal break into or through plies, usually visible from the inside of the tire.

**Radial Crack**—A crack in the outer surface of the tire, usually in the sidewall area proceeding perpendicularly to the bead.

**Tread Cracks (channel or groove)**—Cracks in the base of the tread grooves or voids.

**BUCKLED**—Any gross distortion of the tire body or tread area evidenced by wrinkling on the inside of the casting.

**BUFFED CONTOUR**—The shape of the buffed tire that usually includes a specified radius and width.

**BUFFED RADIUS**—A measure of the buffed surface curvature from shoulder to shoulder.

**BUFFED TEXTURE**—That surface produced by buffing, rasping, or cutting as defined by *The Rubber Manufacturers Association Buffed Textures* (RMA Shop Bulletin No. 29.)

**CASING**—The complete tire structure.

**CEMENT**—An adhesive compound used to provide building tack. May be brushed or sprayed on the buffed surface.

**CHECK TEMPLATE**—A precut pattern used to determine the contour of a buffed tire to check compatibility to a matrix.

**CORDS**—The individual strands forming the plies in a tire.

**CROSS SECTION (C.S.)**—The section width of a tire casing.

## AAR Intermodal Interchange Rules

### C4. Tire Glossary (page 2 of 4)

(Refer to **Figure C-3** and **Figure C-4**.)

**CURE**—The process of vulcanization of rubber by applying heat, pressure, and time.

**CURING TUBES**—Special stubs placed within the tire while curing.

**DIAPHRAGM**—A flexible covering used to encompass part or all of a tire during retreading in some processes.

**ENVELOPE**—A flexible covering used to encompass part or all of a tire during retreading in some processes.

**GAUGE**—Thickness, usually expressed in thirty-seconds of an inch, or by the decimal system, or in millimeters in the metric system.

**INJURY**—A break or cut of any shape caused by a penetrating object or severe scuff or impact.

**INJURY SIZE**—Widest opening in the cord body after skiving and buffing.

**INNER LINER**—The tubeless tire inner surface used to retain the inflation media.

**KINKED (BEADS)**—A sharp permanent bend in the bead wires at one or more points around the circumference of the bead.

**LOAD RANGE**—Used as letters (A, B, C, etc.) in tire identification to identify a given size tire, with its load and inflation limits, when used in a specific type of service as defined in Tire and Rim Association Inc. (or equivalent) yearbooks.

**MATRIX**—Aluminum, rubber, or steel rings or segments that form the cavity in which a tire retread is cured and with which the tread design is formed.

**NAIL HOLE**—A penetration caused by a small, sharp object, ¼ in. maximum diameter.

**PLIES**—Layers of rubber-coating paralleled cords.

**POSTED**—Placement on the immediate premises of the retread shop, available to all personnel involved in the retreading operations and to the management of the shop.

**PROTECTOR PLY**—A ply added primarily for casing protection, which, in some cases, may be removed during retreading.

**REINFORCEMENT (REPAIR)**—Any material, usually rubber and fabric, vulcanized to a tire to add strength to the tire cord body at an injury.

**REPAIRING**—Reconditioning of portions of tires that have been injured by punctures, cuts, breaks, cracks, etc., that restore strength for additional safe service.

**REPAIR MATERIAL**—Any rubber compound or patch material used to make repairs.

### **RETREADING—(Recapping)**

**Full Treading**—Replacement of the worn tread with rubber extending over the shoulders.

**Top Treading**—Replacement of the worn tread area only.

## AAR Intermodal Interchange Rules

### C4. Tire Glossary (page 3 of 4)

(Refer to **Figure C-3** and **Figure C-4**.)

---

**Bead-to-Bead Retreading**—Replacement of the worn tread area and sidewall rubber extending to the bead.

**Precured Tread Retreading**—Replacement of the worn tread areas with pre-vulcanized treads containing the tread design already cured in.

**SECTIONS**—Repairs made to a casing where an injury larger than a nail hole extends through more than 75% of the plies or through the casing in the tread or sidewall areas.

**SEPARATIONS**—Lack of adhesion or cohesion between any adjacent materials in a tire.

**TREAD SEPARATION**—Pulling away of the tread from the tire body.

**RETREAD SEPARATION**—A separation between the tread rubber and the buffed tire casing.

**PLY SEPARATION**—A breakdown of the bond between components in the bead area.

**BELT EDGE SEPARATION**—A breakdown of the bond between components near the edge of the belt plies.

**SHOULDER**—The upper sidewall area of the tire casing immediately adjacent to the tread area.

**SIDEWALL**—That portion of the tire casing between the bead and shoulder.

**SKIVE**—Removal of damaged material prior to making a repair.

**SPLICE**—A junction of the ends of any tire component.

**SPOT (REPAIR)**—The replacement of rubber in an injury that penetrates to no more than 25% of the body plies.

**STITCHING**—A method used to both remove trapped air and improve rubber contact for better adhesion during handling.

**SURFACE REPAIR**—A repair that is in the rubber portion of the casing only; to, but not through any ply.

**SYNTHETIC RUBBER**—Man-made rubber.

**TEXTURE**—(see Buffed Texture)

**TREAD**—That portion of a tire that comes in contact with the road.

**TREAD DESIGN**—The non-skid pattern or design on the tread portion of a tire.

**TREAD GROOVES**—The space between two adjacent tread ribs, lugs, or bars.

**UNDERTREAD (REPLACEMENT)**—The rubber between the base of the tread grooves and the buffed surface.

**VULCANIZATION**—A chemical reaction that takes place under appropriate time, temperature, and pressure and develops desirable tire characteristics and properties. (Also see Cure)

## AAR Intermodal Interchange Rules

### C4. Tire Glossary (page 4 of 4)

(Refer to **Figure C-3** and **Figure C-4**.)

---

**WEATHER CHECKING**—A crazing or cracking of the sidewall surface of the tire attributable to an atmospheric condition rather than to flexing.

**WICKING**—A capillary act of air escapement from the tire casing, or from under any envelope, by means of fabrics or cords.

**ZIPPER RUPTURE**—A circumferential rupture on the sidewall flex area of a steel-cord radial tire.



# AAR Intermodal Interchange Rules

### Figure C-1 Trailer Components—Front/Side

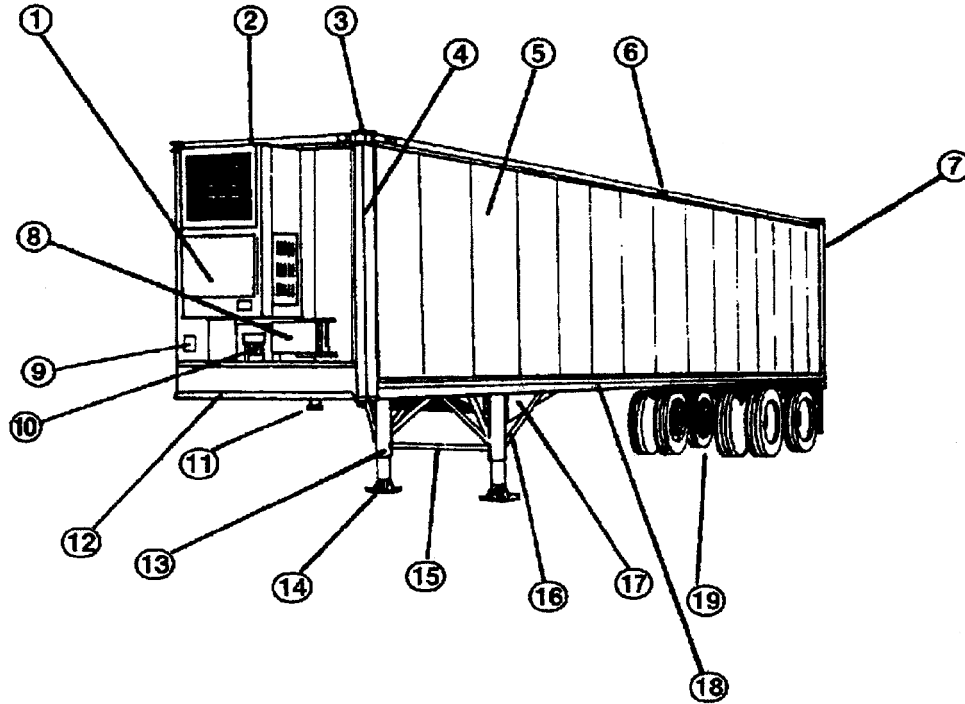

Index No.	Description	Index No.	Description
1	Refrigeration Unit*	11	Kingpin
2	Nose Top Rail	12	Bottom Pickup Rail
3	Corner Cap (Or Casting)	13	Dolly (Landing) Leg
4	Radius Panel	14	Sand Shoe or Dolly Wheels
5	Side Sheet	15	Cross Brace
6	Clearance Light	16	Leg Brace
7	Corner Post (Rear)	17	Leg Mounting Gusset
8	Battery Box*	18	Side Bottom Rail
9	Registration Holder	19	Tandem Assembly (Bogie)
10	Electrical Junction Box & Air Connectors (Glad Hands)		

\*Refrigerated Trailers Only

# AAR Intermodal Interchange Rules

**Figure C-2 Trailer Components—Rear**

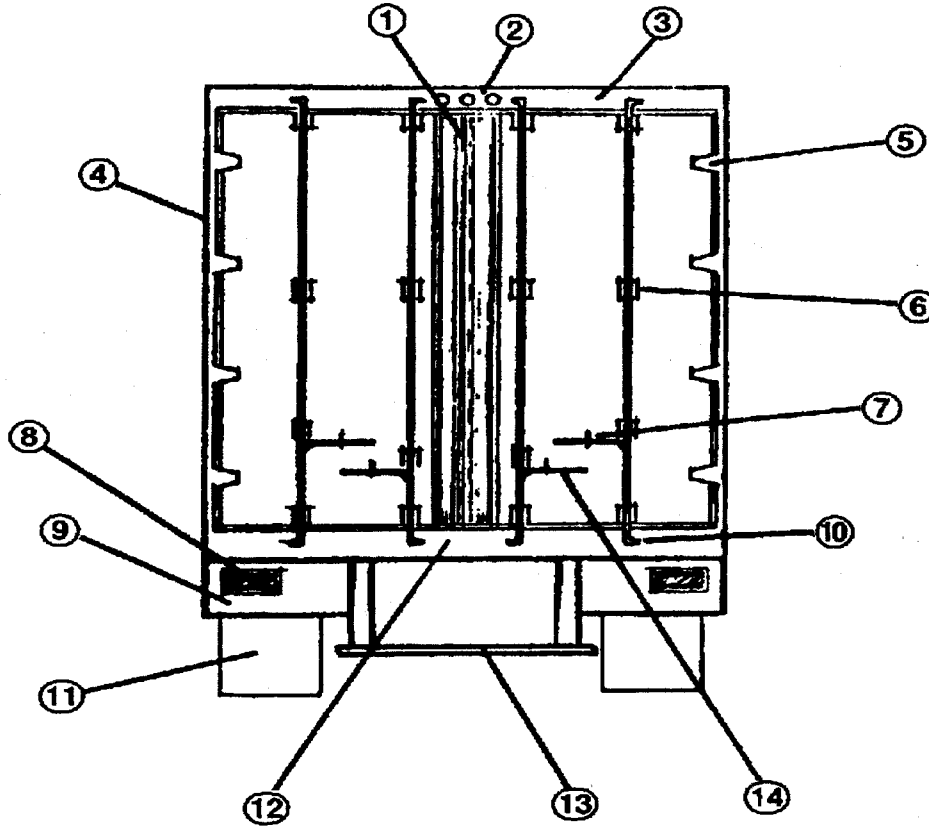

Index No.	Description	Index No.	Description
1	Door Moulding	8	Tail Light Assembly
2	Clearance Lights	9	Mud Flap Bracket
3	Door Header	10	Locking Bar Keeper and Cam
4	Corner Post	11	Mud Flap
5	Door Hinge	12	Rear Sill
6	Locking Bar Guide	13	DOT Underride Guard
7	Locking Bar Latch	14	Locking Bar Handle

Figure C-3 Retread Casing—Tubeless Type

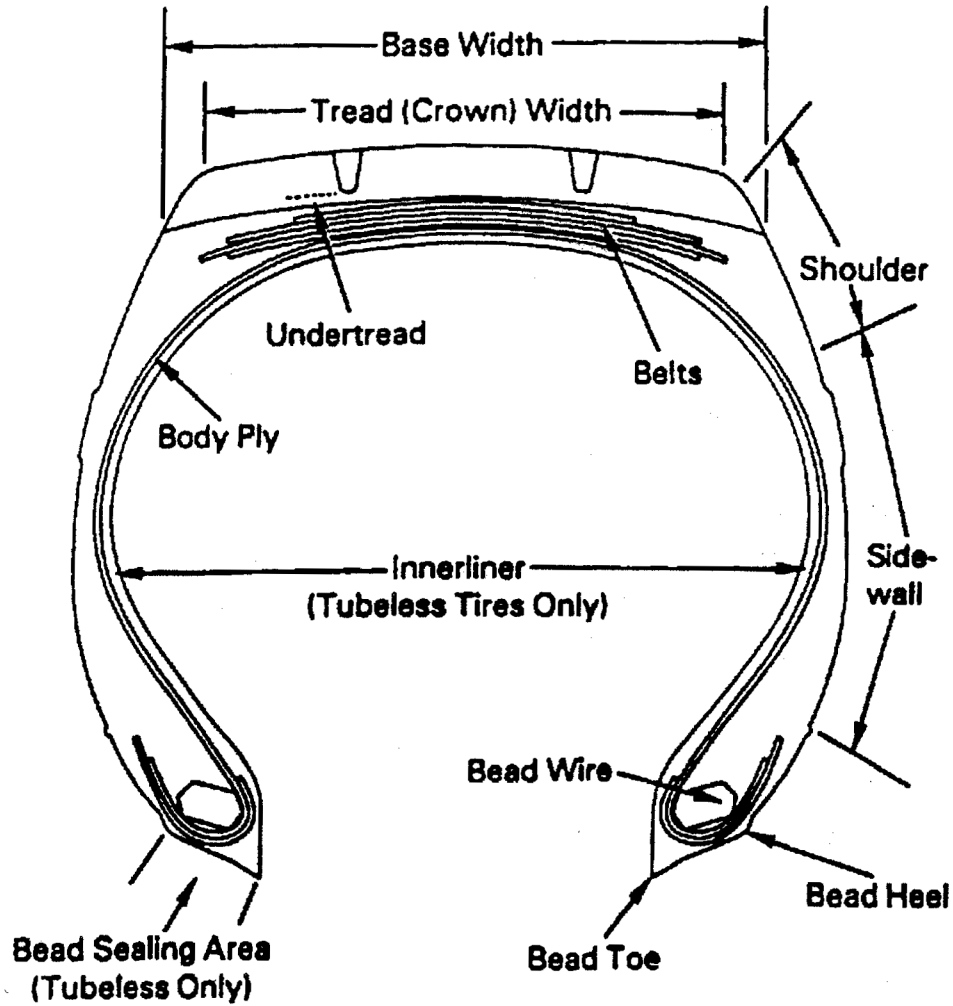
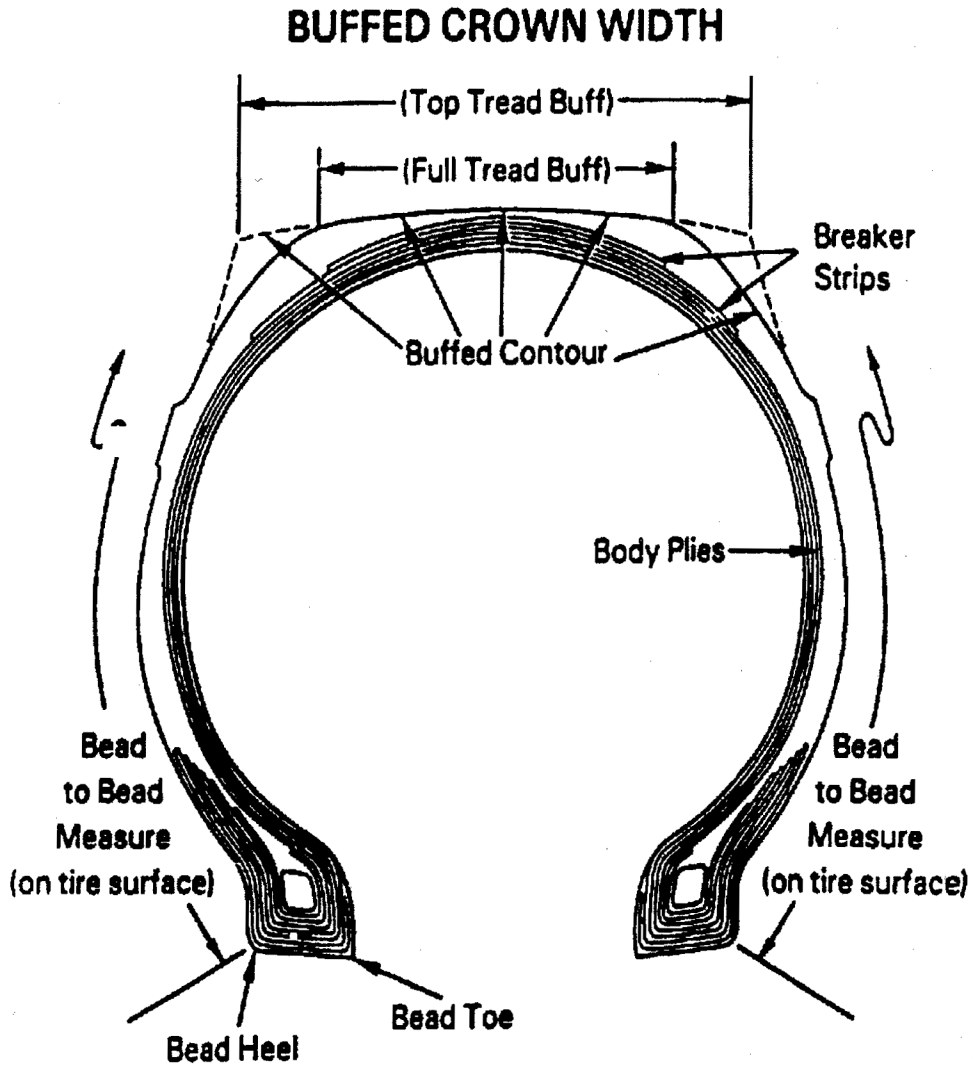

Figure C-4 Buffed Casing—Bias Tubed Type



**APPENDIX D**

**FLAT FILE FORMAT**

**D1. Introduction**

The new “J File” allows for the electronic exchange of damage data. The first field in each record specifies the document type. Based on the first field, the data can be read in the appropriate manner. Thus, multiple damage documents can be contained in the same file. For now, only the format of a J2 document has been specified. Future development could include specifications for other J Forms.

**D2. J File Format**

In the “J File,” each record is specified between ‘{’ and ‘}’ characters. Fields within a record are delimited by the ‘\*’ character. The first field of any record is the document type. For now, only support for the “J2” document type has been specified. Note: All data in the file should be read as a character stream. No assumptions should be made about carriage returns. That is, it should not be assumed that each document record is a new line, despite the fact that some text editors display it this way.

**D3. J2 Format**

The first field of a J2 record is ‘J2.’ After the ‘J2’ field, there are 22 header fields. After the header fields, multiple line items can follow. It is possible to have no line items. Each line item contains 12 fields. Below is a description of the fields in the order they appear in the file. Fields marked with a ‘\*’ can be empty. For the header fields, the “J2 Number” field is the unique identifier. For the line item fields, the “Damage ID” is the unique identifier.

**a. Header Fields**

Field	Data Type
J2 Number	Character String, Max 10 Characters
Bureau	Character String, Max 10 Characters
Entry Date	Data/Time Value
Initial	Character String, Max 4 Characters
Number	Long Integer, Max $2^{31}-1$
Equipment Type	Character String, Max 10 Characters
Delivering RR	Character String, Max 4 Characters
Interchange Type	Character String, Max 10 Characters
Receiving RR	Character String, Max 4 Characters
Station	Character String, Max 50 Characters
Delivery Date	Date/Time Value
Load/Empty	Single Character, ‘L’ or ‘E’
Responsible RR	Character String, Max 4 Characters
Railcar Initial*	Character String, Max 4 Characters
Railcar Number*	Long Integer, Max $2^{31}-1$
Chassis Initial*	Character String, Max 4 Characters
Chassis Number*	Long Integer, Max $2^{31}-1$
RR Issued	Bit Value, 0 or 1
RR Inspector*	Character String, Max 50 Characters
IB Inspector*	Character String, Max 50 Characters
AGS Gate	Bit Value, 0 or 1
Open/Close Status	Single Character, ‘O’ or ‘C’

\*Field can be empty

# AAR Intermodal Interchange Rules

## b. Line Item Fields

Field	Data Type
Damage ID	Long Integer, Max $2^{31}-1$
Job Code	Short Integer, Max $2^{15}-1$
Location	Character String, Max 3 Characters
Whymade Code	Short Integer, Max $2^{15}-1$
Qualifier	Short Integer, Max $2^{15}-1$
Quantity	Short Integer, Max $2^{15}-1$
Size*	Character String, Max 50 Characters
Offset Quantity*	Short Integer, Max $2^{15}-1$
Offset Date*	Date/Time Value
Offset ID*	Short Integer, Max $2^{15}-1$
Offset RR*	Character String, Max 4 Characters
Offset J2 Number	Character String, Max 10
Open/Close Status	Single Character, 'O' or 'C'

\*Field can be empty

## D4. Reading The File

The basic algorithm for reading the file is as follows. Start reading characters until a '{' is encountered. Next, read characters until a '\*' is encountered. This will be the document type field. Read the document type field and decide how to interpret the remaining fields based on the document type. For each document type, read in the appropriate number of header fields. This will be done by searching for a '\*' character for each header field. After reading the header fields, read the line items. If the next field after the header contains a '}', there are no line items. If the next field after the header is not a '\*', there are line items to read. Read in each line item field. This will be done by searching for a '\*' character for each line item field. Keep reading line items until a '}' character is encountered as a field.

# AAR Intermodal Interchange Rules

## APPENDIX E

### SUBSCRIBERS TO THE INTERMODAL INTERCHANGE AGREEMENT

#### E1. Railroad Companies

Arkansas, Louisiana, & Mississippi Railroad Co.	Louisiana & North West Railroad Co.
Angelina & Neches River Railroad	Massachusetts Central Railroad Corp.
Belfast and Moosehead Lake Railway Co.	Middletown and New Jersey Railway
Boston & Maine Corporation	Minnesota, Dakota & Western Railway Co.
Burlington Northern and Sante Fe Railway Co.	Missouri & Northern Arkansas Railroad
Canadian National Railways	New York & Atlantic Railway
Canadian Pacific Railway	Norfolk Southern Railway Company (Includes affiliates per agreement)
Canton Railroad Company	Paducah and Louisville Railway, Inc.
Claremont Concord Railroad Corp.	Pattison Brothers Mississippi River Terminal
Clarendon & Pittsford Railroad Company	Portland Terminal Company
Columbus and Greenville Railway Co.	Providence and Worcester Railroad Co.
Consolidated Rail Corporation	Sand Springs Railway Company
CSX Transportation, Inc.	Southern Railway of British Columbia, Ltd.
Dakota, Minnesota & Eastern RR	Texas South-Eastern Railroad
Delta Valley & Southern Railway Co.	TFM, S.A. de C.V.
East Erie Commercial Railway	Toledo, Peoria & Western Railway Corp.
Florida East Coast Railway Company	Tyburn Railroad Company
Fordyce & Princeton Railroad Co.	Union Pacific Railroad Company
Grafton & Upton Railroad Company	Upper Merion & Plymouth Railroad Co.
H & S Railroad Company	Vermont Railway, Inc.
Kankakee, Beaverville & Southern Rwy.	Wisconsin & Southern Railroad Co.
Kansas City Southern Railway Co.	

# AAR Intermodal Interchange Rules

## E2. Non-Railroad Companies

Advance Transportation Company	Intermodal Association of North America
Agmark Foods, Inc.	Intermodal Shipping Services, Inc.
Alliance Transportation, Inc.	"K" Line America, Inc.
American President Lines	Nippon Yusen Kaisha (NYK Line a/Agents)
American Chassis Leasing	Pacer
APL Limited	PoleStar Transport
Atlantic Container Line	Sea-Land Service, Inc. (Maersk Sealand)
Blue Star North America Ltd.	Sea Star Line
Chicago Bandag, Inc.	S.E. Capital Container Finance Corp.
Container Port Group, Inc.	Stevens Transport
Detroit Salt Company	Tank Solutions
Eagle Systems, Inc.	Tire Management
Evergreen Marine Corporation	Tires Services Co.
Frozen Food Express	Transwest Logistics
Greenbrier Capital Corporation	TTM Logistics, S.A. de C.V.
Hanjin Shipping Company, Ltd.	WTL Rail Corporation
Hapag-Lloyd, A.G.	XTRA Intermodal



# AAR Intermodal Interchange Rules

## APPENDIX F

### COMPLETE MATRIX

This Appendix references a matrix that lists all valid combinations of Job Codes, Why Made Codes, Condition Codes, and Location Codes, and that assigns responsibility for each such combination based on the Rules contained in the main body of these Intermodal Interchange Rules.

This matrix is available as a separate download at AAR's Web site,  
<http://www.aar.com/standards/IntermodalOperations-interchange-rules.html>.

# AAR Intermodal Interchange Rules

THIS PAGE LEFT BLANK INTENTIONALLY

# AAR Intermodal Interchange Rules

## APPENDIX G

### ASSOCIATION TABLE

This Appendix references a table that lists damage items referenced in Appendix F with Why Made Code 01; and associated Job Codes, Job Code Descriptions, and Location Codes also listed in Appendix F.

This table is available as a separate download at AAR's Web site,  
<http://www.aar.com/standards/IntermodalOperations-interchange-rules.html>.

# AAR Intermodal Interchange Rules

THIS PAGE LEFT BLANK INTENTIONALLY